

Data Acquisition Form for FMS Force Measuring Rollers RMGZ900 serie



To suggest a specific offer, we need some information about your application.
Please complete the data sheet as much as possible and return it to us. Thank you.

**Please fill in and send
to the below address.**

Name : _____	Phone : _____
Company : _____	Project : _____
Material : _____	
Material width	max: _____ min: _____ [mm]
Material speed v	: _____ [m/min]
Total material tension	max: _____ min: _____ [N]
Roller diameter	: _____ [mm]
Roller surface or coating	: _____
Required bearing lifetime	: _____ [h]
Sensor type / options:	
<input type="checkbox"/> with straight plug (standard)	<input type="checkbox"/> with right-angle plug (H14)
<input type="checkbox"/> Temperatures up to 150°C (H16)	
<input type="checkbox"/> other: _____	

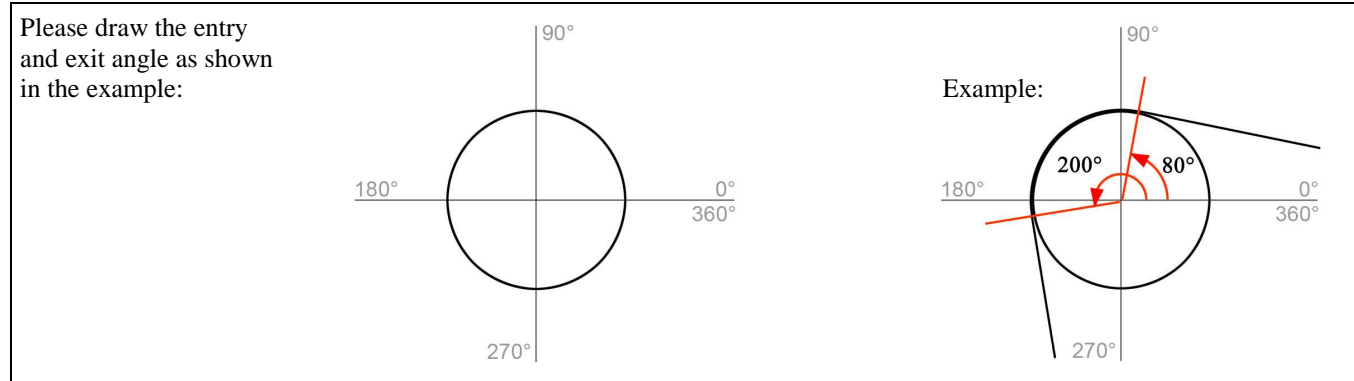

Remarks / Drawing:

World Headquarters:
FMS Force Measuring Systems AG
 Aspstrasse 6
 8154 Oberglatt (Switzerland)
 Phone + 41 44 852 80 80
 Fax + 41 44 850 60 06
 info@fms-technology.com

FMS USA, Inc.
 925 East Rand Road · Suite 207
 Arlington Heights, IL 60004
 Phone 847 392 7872
 Fax 847 392 7873
 fmsusa@fms-technology.com

FMS UK
 Highfield, Atch Lench Road
 Church Lench
 Evesham WR 11 4UG
 Phone 1386 871023
 Fax 1386 871021
 fmsuk@fms-technology.com