

EMGZ 470 A.W/472 A.W PROFIBUS® Tension Measuring Amplifier

Microprocessor controlled
High performance and speed

Functions parameterized via PROFIBUS®
Easy set-up and programming

IP 67 aluminium housing
Can be used in harsh environments

Galvanically isolated
Protected against electrical noise



● Functional Description

The EMGZ 470 A.W/472 A.W digital tension measuring amplifiers are suitable for tension measurement with all FMS force sensors. The complete operation is performed by the integrated PROFIBUS® connection. Design and function are optimized for tension measuring applications.

The mV signal of the sensors are pre-amplified with a fixed gain and then fed directly to the A/D converter.

Signal conditioning is done digitally. The PROFIBUS® interface provides flexible signal processing by the control unit. For maximum flexibility, two different PROFIBUS® operating modes are possible:
„Feedback with status“ (3 data bytes)
and „Full Control“ (6 data bytes).

EMGZ 470 A.W/472 A.W PROFIBUS® • Dimensions in mm

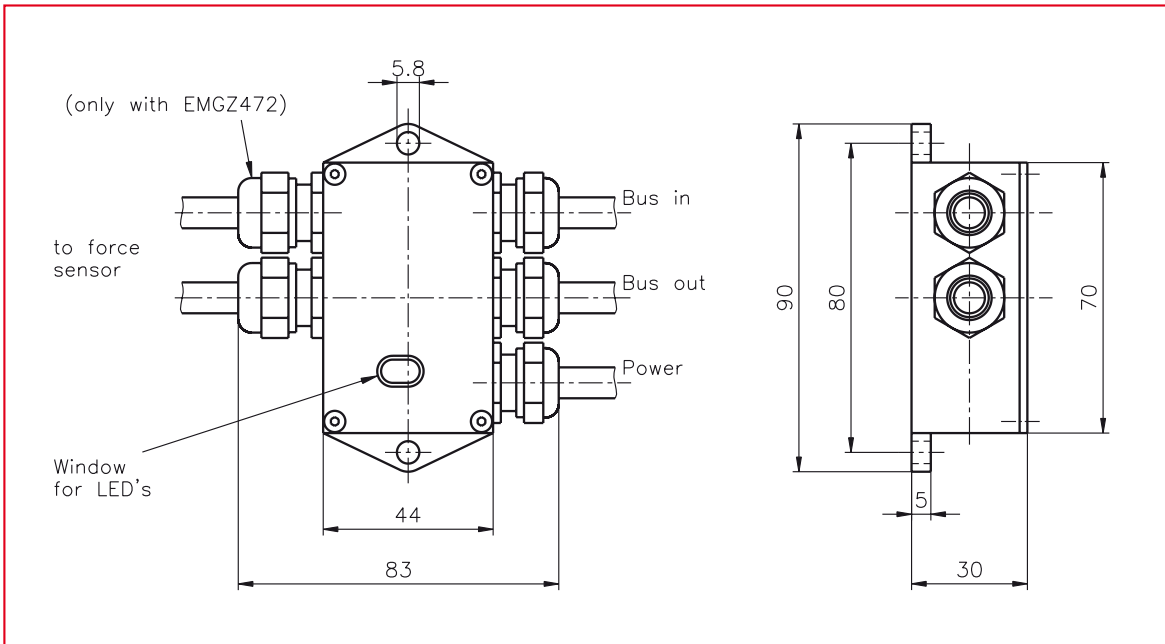

EMGZ 470 A.W/472 A.W Series • PROFIBUS® and sensor wiring

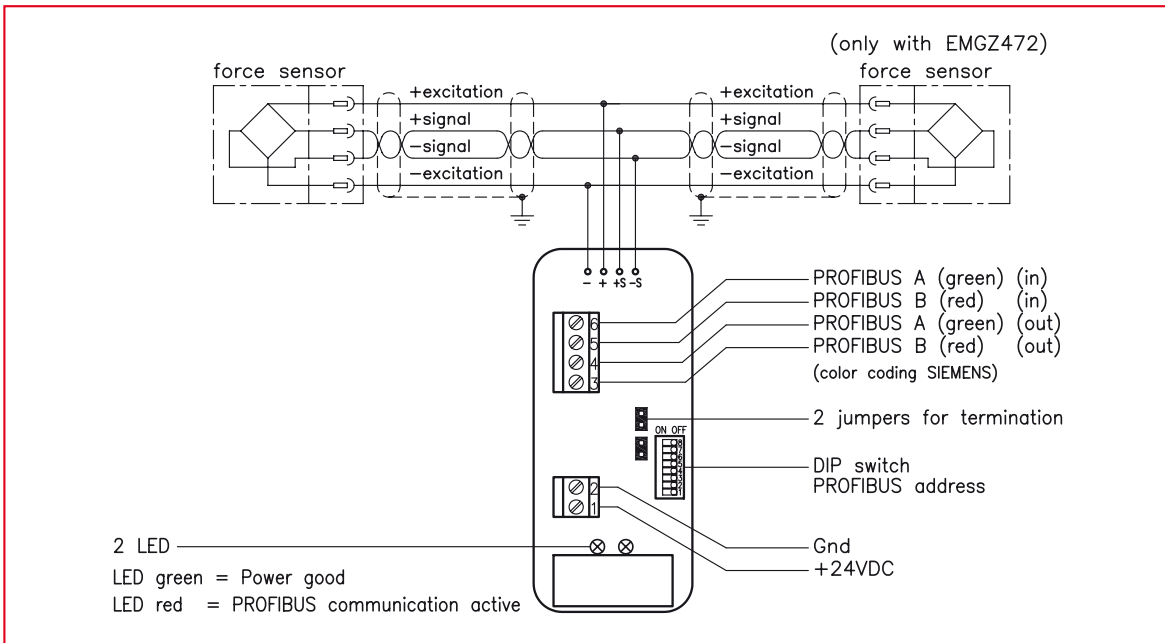

EMGZ 470 A.W/472 A.W PROFIBUS® • Technical data	
Force sensors	EMGZ 470 A.W: For connection of one force sensor (1 x 350 Ω) EMGZ 472 A.W: For connection of two force sensors (2 x 350 Ω)
Sensor supply voltage	4 VDC
Input signal	0...7.2 mV (max. 9.92 mV)
Resolution A/D converter	± 2048 Digit (12 Bit)
Measuring error	< 0.05 %
Measuring rate	1 ms
Operation	Entirely by PROFIBUS®
Feedback value	Integral number ± 32767
PROFIBUS® protocol	PROFIBUS® DP slave (EN 50 170)
PROFIBUS® data transfer rate	Up to 12 Mbaud
PROFIBUS® address	0...125 (by DIP switch)
PROFIBUS® operating modes	Full control, Feedback with status
Connection	3 cables ø 8...10 mm through PG glands (Bus in, Bus out, Power)
Termination	By 2 jumpers
Required cables	PROFIBUS® cable type A, STP 2 x 0.342
Power supply	24 VDC (18...36 VDC) / 0.1 A
Temperature range	- 10...60 °C
Protection class	IP 67
Weight	0.5 kg

Note:

When implementing a real-time control loop ensure that the application-specific PROFIBUS® protocol is short enough timewise to provide sufficient control dynamics.

FMS' Product Portfolio and System Solutions



The product line Force Sensors provides products, solutions and related services that increase industrial productivity, energy efficiency and high quality output. Its force sensors, tension measuring rollers and pillow block based designs are of premium quality and ultra durable.



The product line Electronics facilitates tension monitoring, close loop tension control and web guiding systems. Key technologies include high-performance tension amplifiers and PID-controllers, as well as products to accurately and consistently control material position in continuously manufactured products.



The main focus of the FMS Web Guiding business is to provide customers with products and solutions for web detection and web positioning. Its steering frames, drives, controllers and material sensors provide an excellent coverage of the most important applications. The industries served include converting, printing, label processing and packaging.

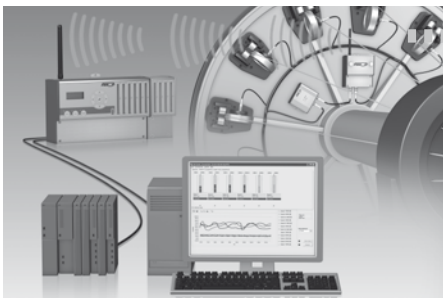

RTM (Radio Transmitted Tension Monitoring) delivers system solutions across the cable production value chain. These innovative systems utilise force measuring rollers to capture the tension of individual wires or strands, and then securely transmit this data from the rotating to the static part of the machine. The systems are designed with fully compatible components. Production rates and product quality on rotating strand-handling machinery are significantly improved.



Special Application Fields facilitates solutions in **vacuum** applications or in potentially explosive atmospheres. A sophisticated range of interface options including systems such as **PROFINET, Ethernet/IP, Profibus** and **CAN-bus** provide quick and efficient integration of FMS products into the existing communication and control infrastructure of your company.

World Headquarters:

FMS Force Measuring Systems AG
Aspstrasse 6
8154 Oberglatt (Switzerland)
Phone + 41 44 852 80 80
Fax + 41 44 850 60 06
info@fms-technology.com

FMS USA, Inc.
2155 Stonington Avenue
Suite 119
Hoffman Estates, IL 60169
Phone + 1 847 519 4400
Fax + 1 847 519 4401
fmsusa@fms-technology.com

FMS UK
Highfield, Atch Lench Road
Church Lench
Evesham WR 11 4UG
Phone + 44 1386 871023
Fax + 44 1386 871021
fmsuk@fms-technology.com

FMS Italy
Via Baranzate 67
20026 Novate Milanese
Phone + 39 02 39487035
Fax + 39 02 39487035
fmsit@fms-technology.com