

Data Acquisition Form

Force sensors for LIVE SHAFT rolls



Contact Information

Company	Project
Name, first name	Tel.
Email	

Process Data

Min. material tension	N	Max. material tension	N
Tension / mm web width	N	Roller weight	N
Web width B	mm	Rotation speed roll	rpm
Journal / shaft diameter d_j	mm	Roll diameter d_R	mm
Wrap angle α	°	Entry angle β	°
Exit angle γ	°	Material speed	m/Min
		Material	

Options (depending on force sensor series and size)

H10	covers not part of scope of supply
H13	open covers for both sides
H14	right-angle connector, replaces straight connector
H15	connector offset 90°, red point on connector side
H16	temperature range up to 120°C (248°F)
H18	water tight, straight connector
H19	grease nipple
H21	electrical connection with PG gland, 5 m (16 ft.) cable
H29	aggressive media (acids)
H30	aggressive media (solvents, hydrocarbons), silicone free
H31	vacuum to 1E-7 hPa , 1E-5 Torr, up to 120°C (248°F)
H32	vacuum up to 150°C (302°F), pg-gland, 5 m (16 ft.) cable
H33	temp. up to 150°C (302°F), pg-gland, 5 m (16 ft.) cable

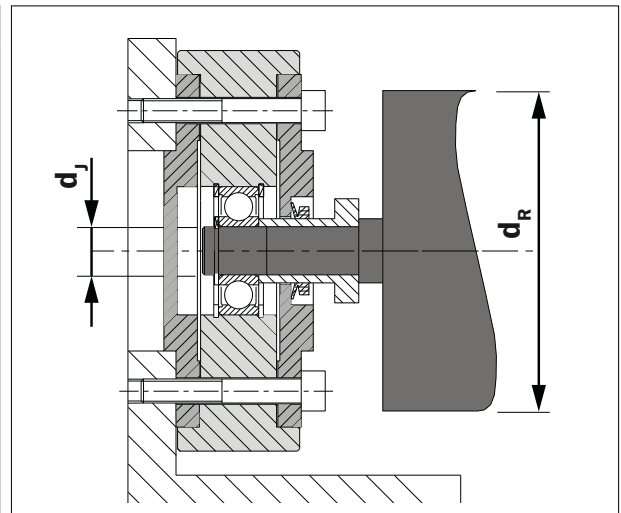

Force Sensor Series Preferences

LMGZ-Series	C-Series	LMGZD-Series	F-Series	A-Series
-------------	----------	--------------	----------	----------

Installation (Please provide a sketch of the web path including entry and exit angle, if possible)

Example

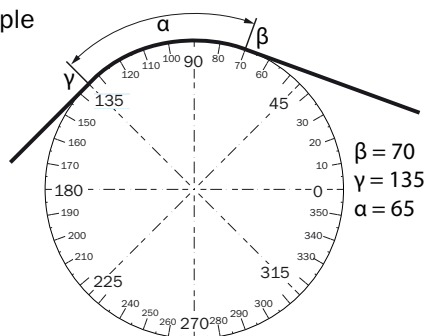

Your sketch

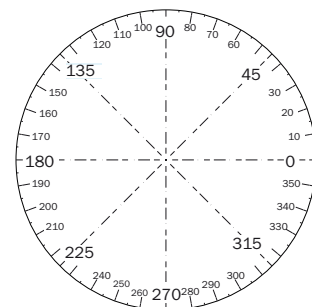

Related Products

Install. bracket	Amplifiers	Cables	Connectors	Nuts & Bolts
------------------	------------	--------	------------	--------------