

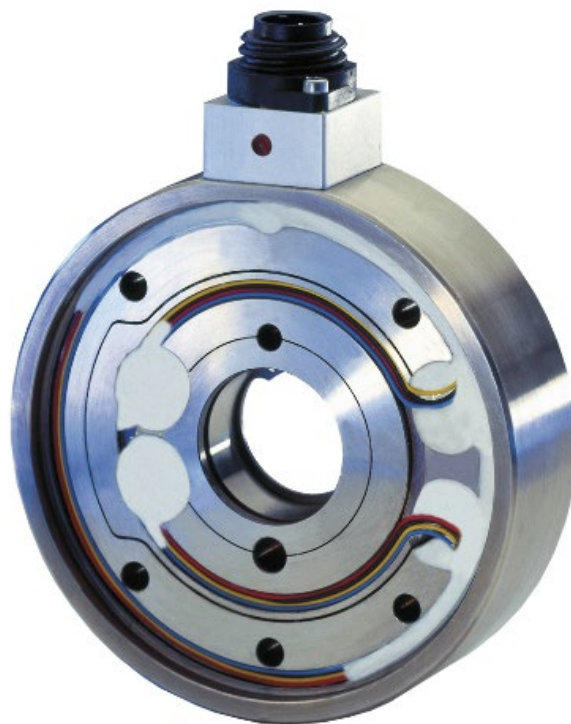

## Installation Instructions LMGZD-Series

Highly precise, stainless steel force measuring bearing with  
a measuring range > 500:1

Document Version 2.10  
Issue Date / Author 06/2021 NS



**Diese Bedienungsanleitung ist auch in Deutsch erhältlich.  
Bitte kontaktieren Sie Ihre nächstgelegene FMS Vertretung.**

# 1 Table of contents

<b>1</b>	<b>TABLE OF CONTENTS .....</b>	<b>2</b>
<b>2</b>	<b>SAFETY INSTRUCTIONS.....</b>	<b>3</b>
2.1	Presentation of safety information .....	3
2.1.1	Danger that could result in minor or moderate injuries.....	3
2.1.2	Note regarding proper function .....	3
2.2	General safety information .....	3
<b>3</b>	<b>PRODUCT INFORMATION.....</b>	<b>4</b>
3.1	Product description .....	4
3.2	Functional description .....	4
3.3	Overview and designation.....	4
3.4	Order code .....	5
3.5	Scope of delivery.....	5
<b>4</b>	<b>INSTALLATION.....</b>	<b>7</b>
4.1	Installation conditions .....	7
4.2	Bearings .....	7
4.3	Shaft ends .....	8
4.4	Machine frame .....	9
4.5	Installation inside the machine frame.....	10
4.6	Installation Outside the machine frame.....	12
4.7	Mounting brackets .....	13
4.8	Electrical connections .....	15
4.8.1	Connection to dual-channel measuring amplifier .....	15
4.8.2	Connection to two single channel measuring amplifiers .....	16
<b>5</b>	<b>MAINTENANCE .....</b>	<b>17</b>
<b>6</b>	<b>TECHNICAL DATA .....</b>	<b>18</b>
<b>7</b>	<b>DIMENSIONS .....</b>	<b>19</b>

## 2 Safety instructions

All safety related regulations, local codes and instructions that appear in the manual or on equipment must be observed to ensure personal safety and to prevent damage to the equipment connected to it. If equipment is used in a manner not specified by the manufacturer, the protection provided by the equipment may be impaired.

Do not stress the equipment over the specification limits neither during assembly nor operation. To do so can be potentially harmful to persons or equipment in the event of a fault to the equipment.

### 2.1 Presentation of safety information

The following safety symbols appear in this manual.

#### 2.1.1 Danger that could result in minor or moderate injuries



Danger, warning, caution

Failure to follow wiring instructions in this manual may result in equipment damage or personal injury.

#### 2.1.2 Note regarding proper function



Note

Note regarding proper operation  
Simplification of operation  
Ensuring function

### 2.2 General safety information



The Force Measuring Rollers may not be stressed over the specification limits neither during assembly nor operation. The unit's overload protection value may not be exceeded.



The attachment points for the Force Measuring Rollers on the machine frame must be properly designed. The bearings need to be appropriately mounted.



For proper installation and operation, follow the electrical wiring diagram and instructions in this manual.

## 3 Product information

### 3.1 Product description

The force measuring bearings of the LMGZD-Series, designed for the measurement of tension on continuous material processing lines where live shaft idler rolls are utilized. The measuring range of 500:1 allows reproducible, highly precise measurements on widely varying web widths and materials. The mechanical overload protection of up to 10-times the nominal force provides unsurpassed robustness. With the superior performance of the LMGZD-Series, accurate tension readings are obtained even with low web wrap angles and high roll weights. For installations where a Pillow Block mount is required the optional bracket can be utilized.

### 3.2 Functional description

The LMGZD-Series force measuring sensor combines the bearing seat and the force sensor within the same housing, thus minimizing the required installation space. The substantial overload protection translates to eliminated / minimized calibration issues due to machine upset conditions. The movement of the bending beam, which is proportional to the applied force, is detected by strain gauges arranged in a full bridge circuit and then converted into an electrical signal. This simple measurement principle delivers precise results even with low material tension and small web wrap angles. The Red Point, as located on the sensor body, should be aligned with the direction of the resultant force due to web tension.

### 3.3 Overview and designation

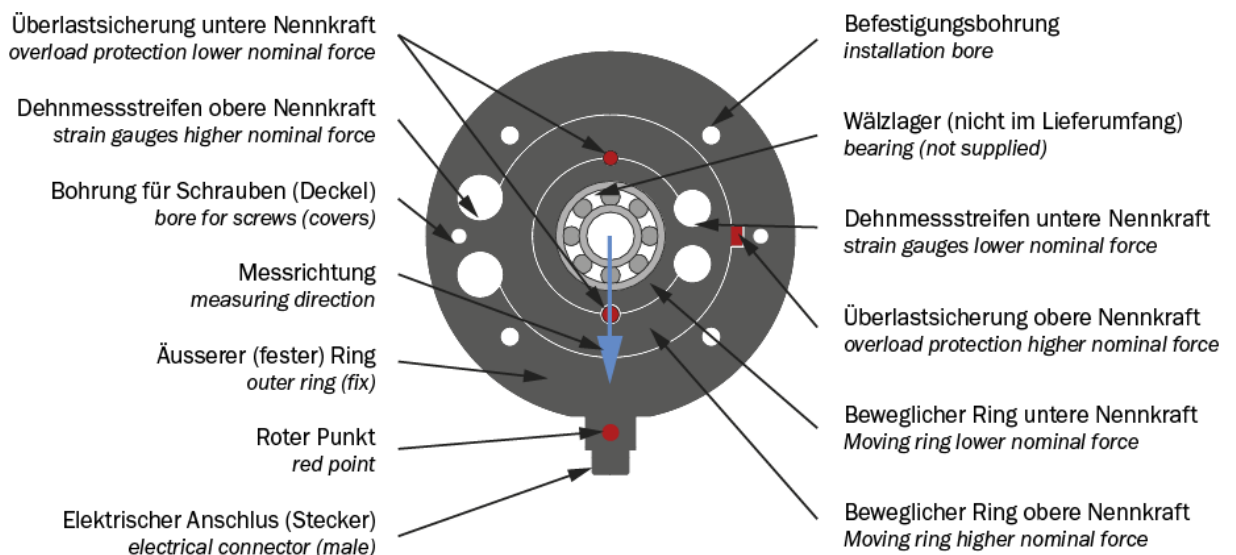

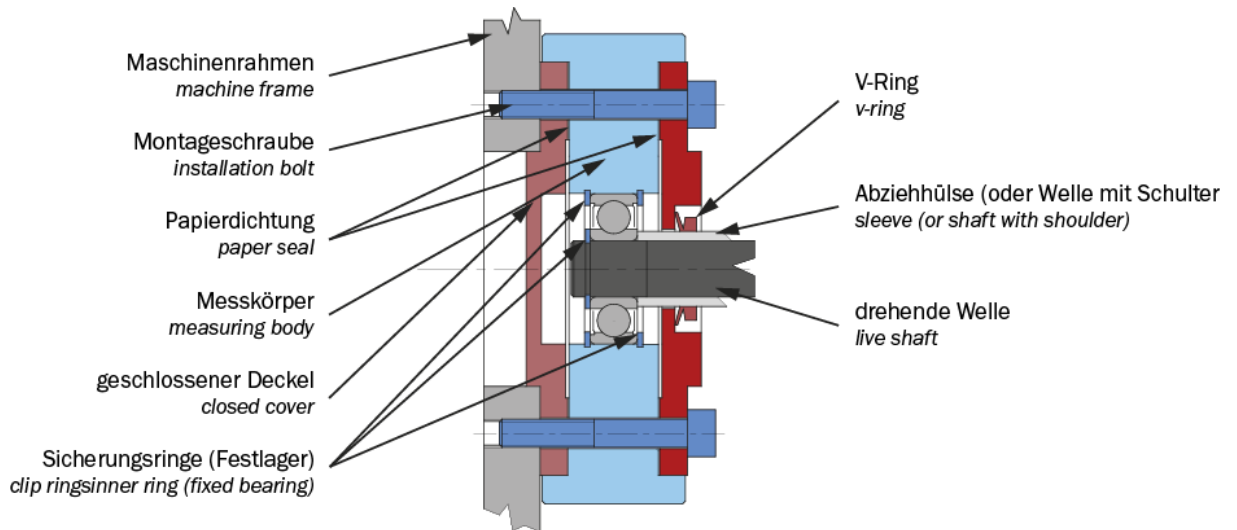

Figure 1: Overview and designation

LMGZD\_BA\_Manual.ai

### 3.4 Order code

LMGZD-Series : Order code					
LMGZD	202	.500	.50	.15	.H13.H14
					Options
					Shaft diameter in mm
					Low nominal force in N
					Nominal force
					Size
					Series

Figure 2: order code

Datasheet\_LMGZD\_series.indd

### 3.5 Scope of delivery

#### Included in scope of delivery

force sensor, straight connector (female), open cover, closed cover, V-ring, clip ring, distance ring (for narrower bearing), thinner clip ring (for wider bearing)

#### Options

- H13 open covers for both sides, additional scope of supply 1 pcs. V-ring
- H14 right-angle connector in scope of supply, replaces straight connector
- H16 temperature range up to 120 °C (248 °F)
- H19 grease nipple
- H21 electrical connection with PG gland with 5 m (16 ft.) cable, replaces connector

- H29 increase chemical resistance against aggressive media, especially acids (please indicate chemical composition), temperature range up to 120 °C (248 °F)
- H30 increase chemical resistance against aggressive media, especially hydrocarbons and solvents (please indicate chemical composition), temperature range up to 120 °C (248 °F)
- H31 for vacuum applications to 1E-7 hPa , 1E-5 Torr, temperature range up to 120 °C (248 °F)
- H32 vacuum to 1E-7 hPa , 1E-5 Torr, up to 150 °C (302 °F), with pg-gland and 5 m (16 ft.) cable
- H33 temperature range up to 150 °C (302 °F), with pg-gland and 5 m (16 ft.) cable

**Accessories**

Bearing, installation bracket, prefabricated cable (specify length) with connector (straight or right-angle)

## 4 Installation

### 4.1 Installation conditions

The Force Measuring Roller are defined as “partly completed machinery” according to the Directives 2006/42/EC, article 2. In order to assure a proper functionality of the parts and assure the essential safety requirements of operators working with it, the following conditions for the assembly must be met:



The Force Measuring Rollers may not be stressed over the specification limits neither during assembly nor operation. The unit's overload protection value may not be exceeded.



The mounting points for the Force Measuring Rollers on the machine frame must be properly designed. The bearings need to be appropriately mounted.



For proper installation and operation, follow the electrical wiring diagram and instructions in this manual.

### 4.2 Bearings

We recommend the use of self-aligning ball bearings or spherical roller bearings.

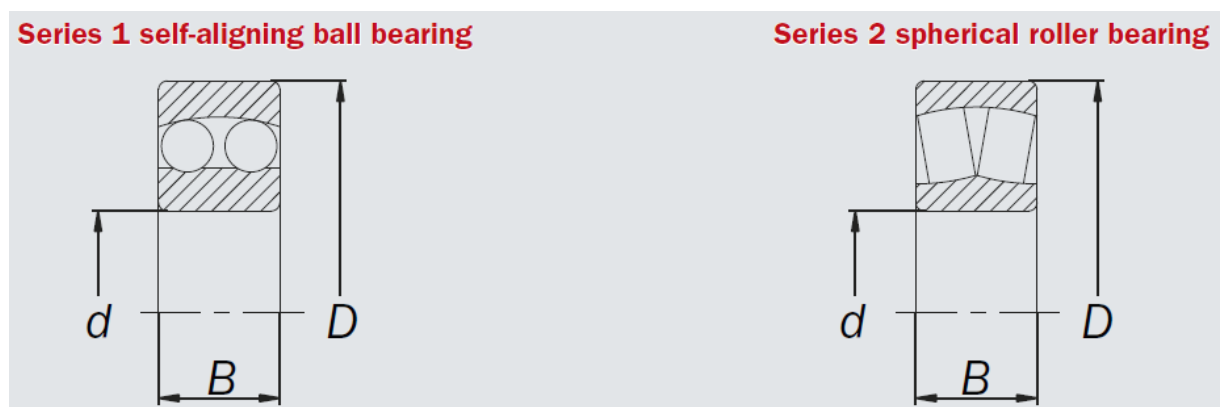

Figure 3: bearing types

Datasheet\_LMGZ\_series.indd

LMGZD-Series : Bearings						
Force Sensor	Suitable bearing (bearing not in scope)					
Type	Type	Dimensions mm (in.)				
		d		D		B
LMGZD202	2202	15	(0.5906)	35	(1.3780)	14 (0.5512)
LMGZD205	22205	25	(0.9843)	52	(2.0472)	18 (0.7087)
LMGZD307	21307	35	(1.3780)	82	(3.2284)	21 <sup>1)</sup> (0.8268)
LMGZD308	22208	40	(1.5748)	80	(3.1496)	23 (0.9055)

Table 1: bearings

Datasheet\_LMGZD\_series.indd

### 4.3 Shaft ends

The shaft ends which receive the inner rings of the rolling bearings must be manufactured as follows.

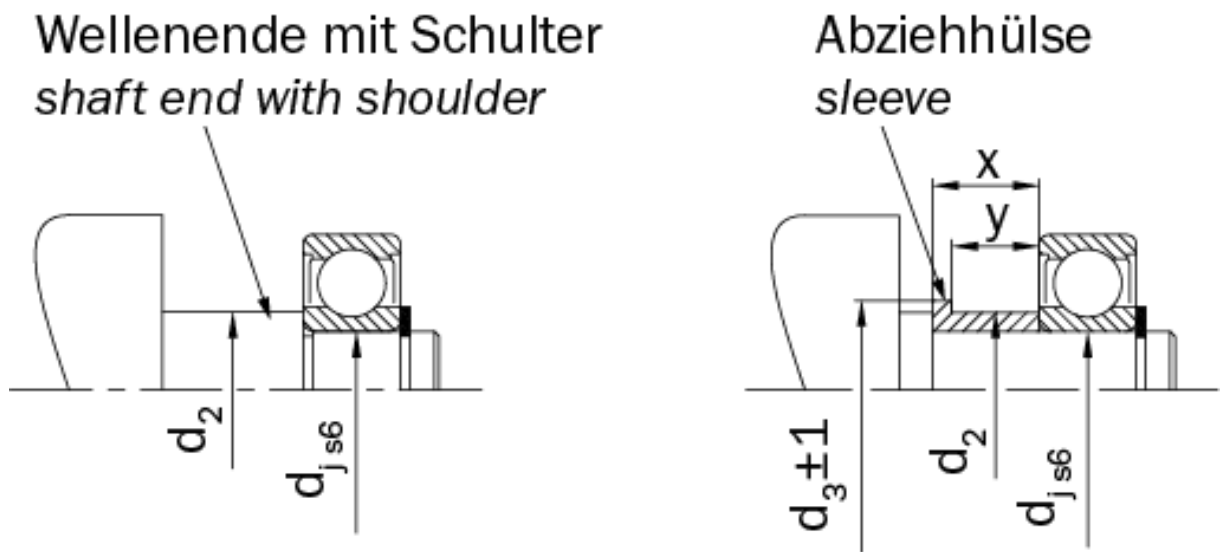

Figure 4: shaft end

LMGZD\_BA\_Manual.ai

Dimensions shaft ends (in mm)			
Baugrösse	$d_j$	$d_2$	$d_3$
LMGZD202	15	20	30
LMGZD205	25	31	41
LMGZD307	35	44	60
LMGZD308	40	48	60

Table 2: dimensions shaft ends

The sleeve ensures that the occurring force during the removal of the bearing is only applied to the inner ring of the bearing. The sleeve is not included in the scope of delivery.

If a shaft with shoulder is used, the rolling bearing may be damaged while removing it from the shaft. In that case, a new rolling bearing must be used after each removal.



### 4.4 Machine frame

The force sensors are centered with a pilot in the machine frame. 4 threaded bores are required for each force sensor.

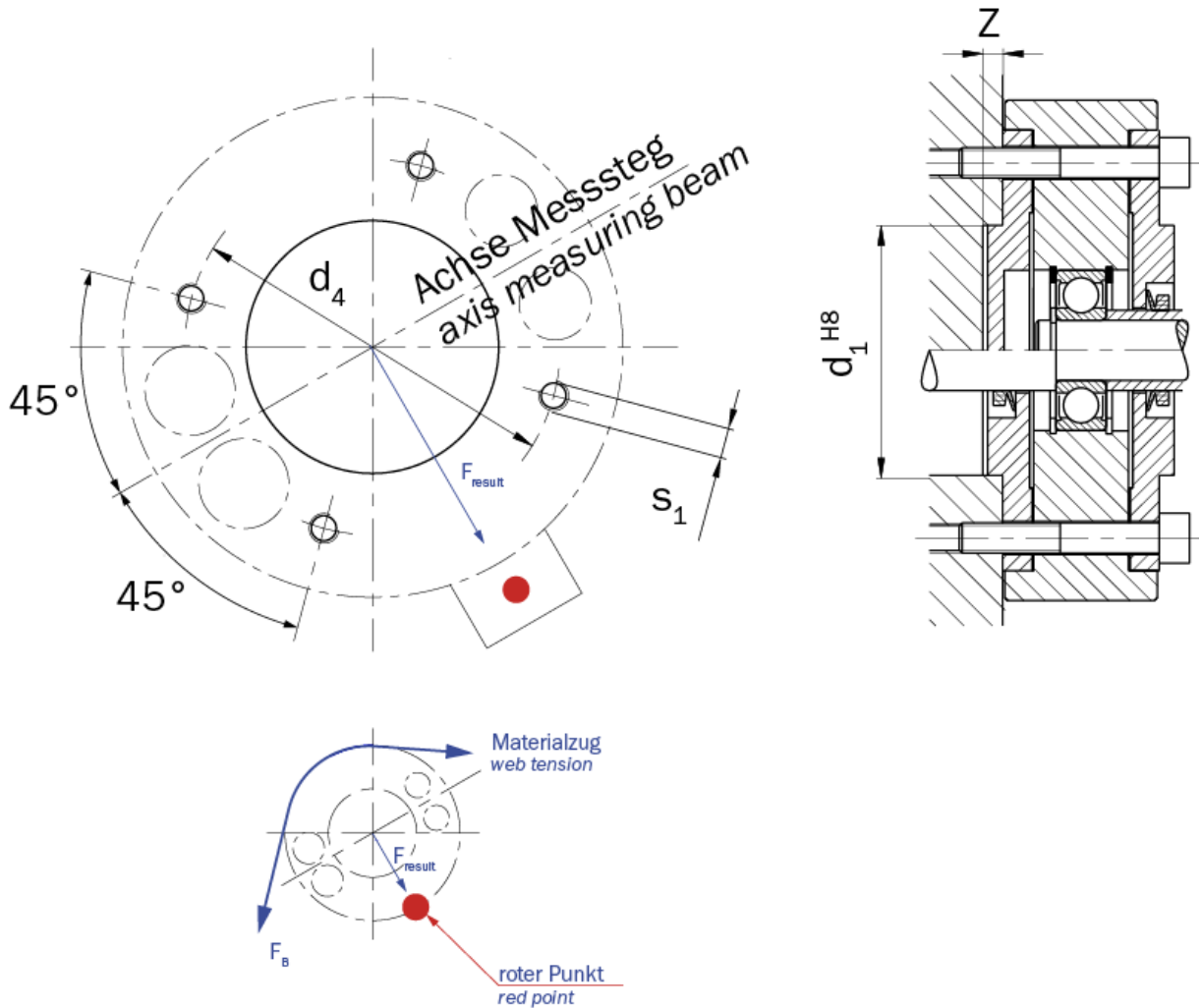

Figure 5: dimensions machine frame

LMGZD\_BA\_Manual.ai

Dimensions machine frame (in mm)				
Baugrösse	$d_4$	$d_1$	$s_1$	Z min.
LMGZD202	95	70	M6	5
LMGZD205	135	100	M8	5
LMGZD307	175	130	M10	5
LMGZD308	175	130	M10	5

Table 3: dimensions machine frame

## 4.5 Installation inside the machine frame

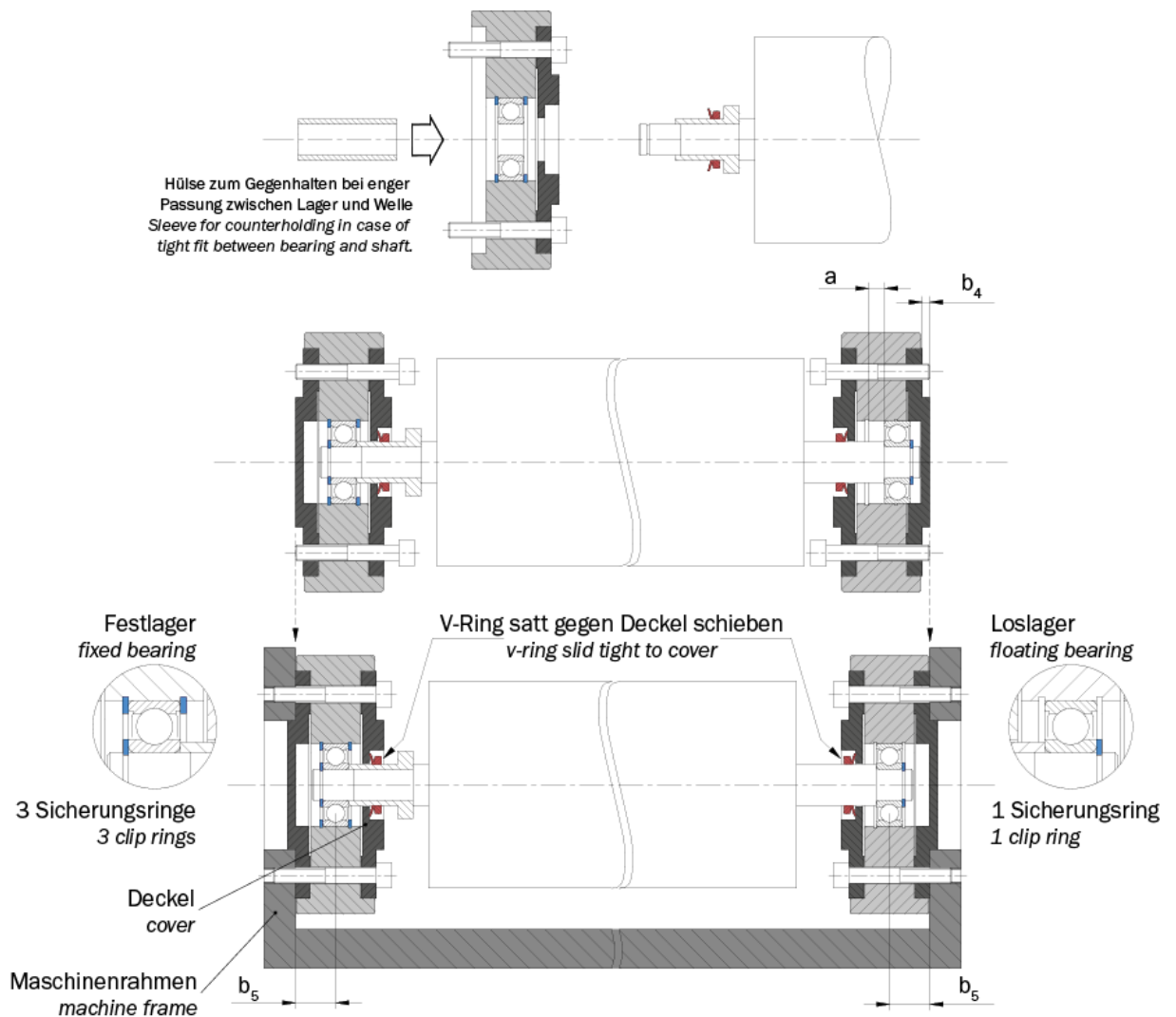

**Figure 6: Installation inside the machine frame**

### Fixed bearing

- Clean the shaft, check tolerance and cylindric shape of the bearing seat.
- Slide sleeve with v-ring onto to the shaft or slide v-ring onto the shaft end.
- Check for correct orientation of the sealing lip.
- Remove both covers from the force sensor. Types with overload protection with pins: Remove pins, mark them and store them safely.
- Insert bearing into the force sensor.
- Fixate bearing by installing 2 clip rings on each side of the bearing. The second clip ring can be taken from the force sensor of the floating bearing.
- Set open cover and paper seal into the correct side of the force sensor, so that the orientation of red point and connector correspond to the required installation position.
- Insert 4 screws into the force sensor.
- Press the bearing with force sensor onto the shaft. The force should only be applied to the inner ring of the bearing. Use a short length of mild steel tube as tool.
- Fixate the bearing to the shaft with a clip ring.

- Types with overload protection with pins: Insert 2 straight pins into force sensor.
- Mount closed cover and paper seal to the force sensor.
- Fasten the covers with the mounting screws.

#### **Floating bearing**

- Clean the shaft; check tolerance and cylindric shape of the bearing seat
- Slide sleeve with v-ring onto to the shaft or slide v-ring onto the shaft end.
- Check for correct orientation of the sealing lip.
- Remove both covers from the force sensor. Types with overload protection with pins: Remove pins, mark them and store them safely.
- Remove clip ring from the force sensor. Insert bearing loosely into force sensor.
- Set open cover and paper seal into the correct side of the force sensor, so that the orientation of red point and connector correspond to the required installation position.
- Insert 4 screws into the force sensor.
- Press the bearing with force sensor onto the shaft. The force should only be applied to the inner ring of the bearing. Use a short length of mild steel tube as tool.
- Fixate the bearing to the shaft with a clip ring.
- Types with overload protection with pins: Insert 2 straight pins into force sensor.
- Mount closed cover and paper seal to the force sensor.
- Fasten the covers with the mounting screws.

#### **Inserting the roll in the machine frame**

- Slide floating force sensor towards the roll as far as possible
- Insert roll with force sensors into the machine frame.
- Align fixed bearing force sensor in regards of the orientation of the red point and place shoulder into the pilot.
- Tighten 4 screws.
- Align floating bearing force sensor in regards of the orientation of the red point and place shoulder into the pilot.
- Tighten 4 screws.
- Check for free spinning roll.
- Slide the two v-rings tight to the opened covers.

## 4.6 Installation Outside the machine frame

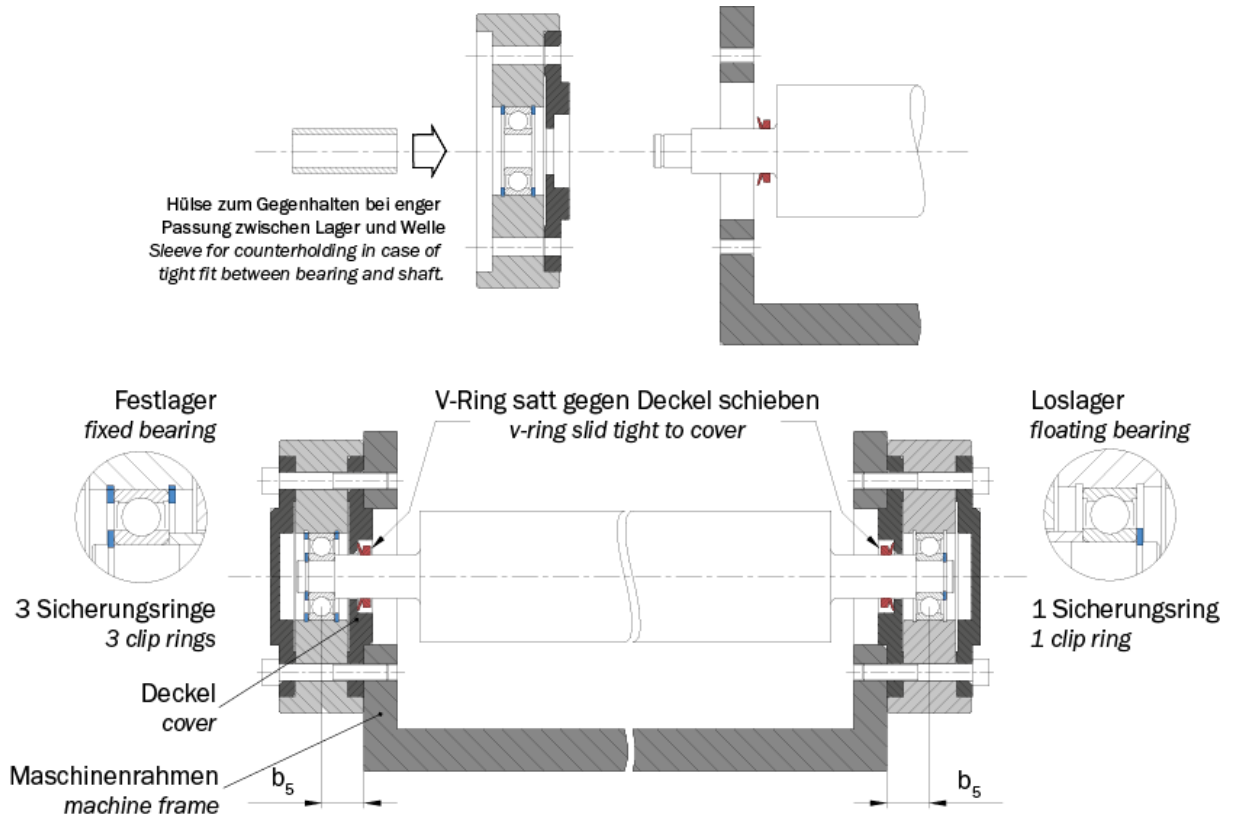

**Figure 7: Installation outside the machine frame**

First, place the roll in the machine frame and shift it at the appropriate position.

The other installation steps are similar to the installation inside.

## 4.7 Mounting brackets

Mounting brackets GMGZ are available as accessories for the LMGZD-series.

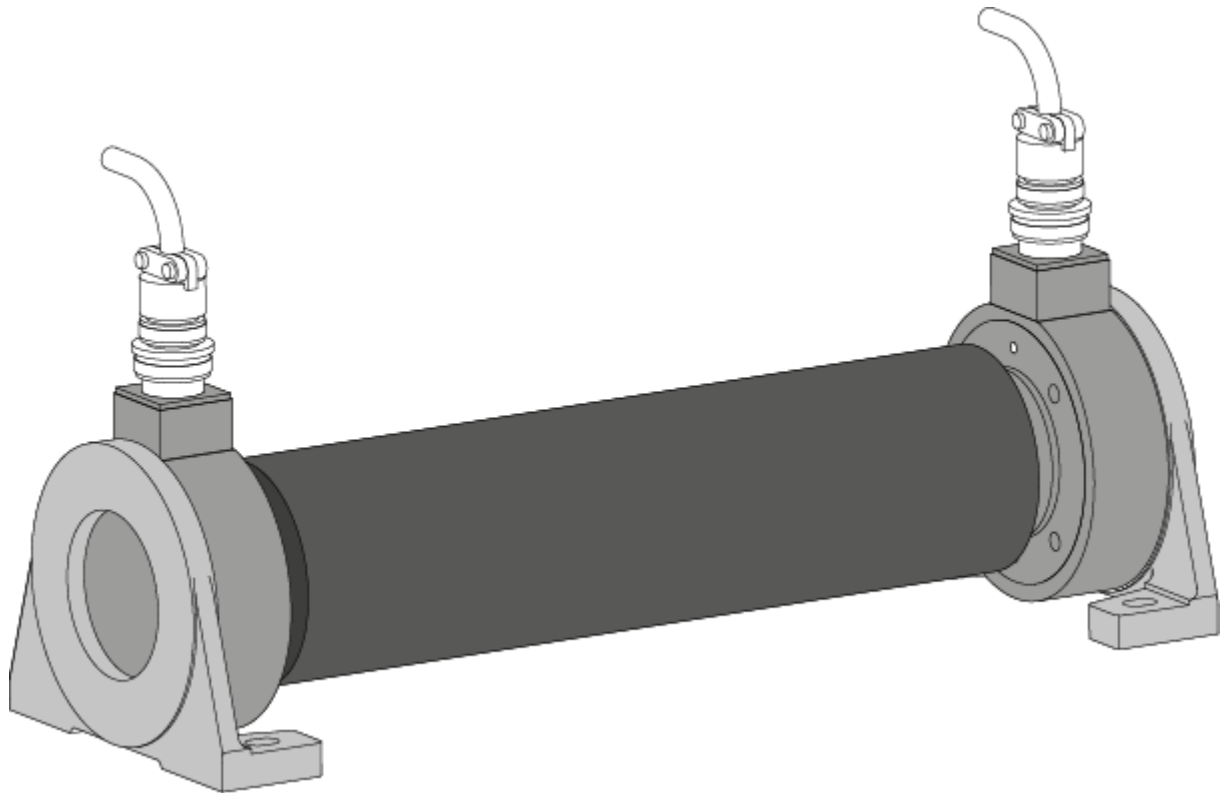

**Figure 8: bracket installation inside**

- The force sensors are mounted to the roll as described earlier
- The brackets are mounted to the force sensors with 4 screws each
- The completely assembly is installed on the machine frame.

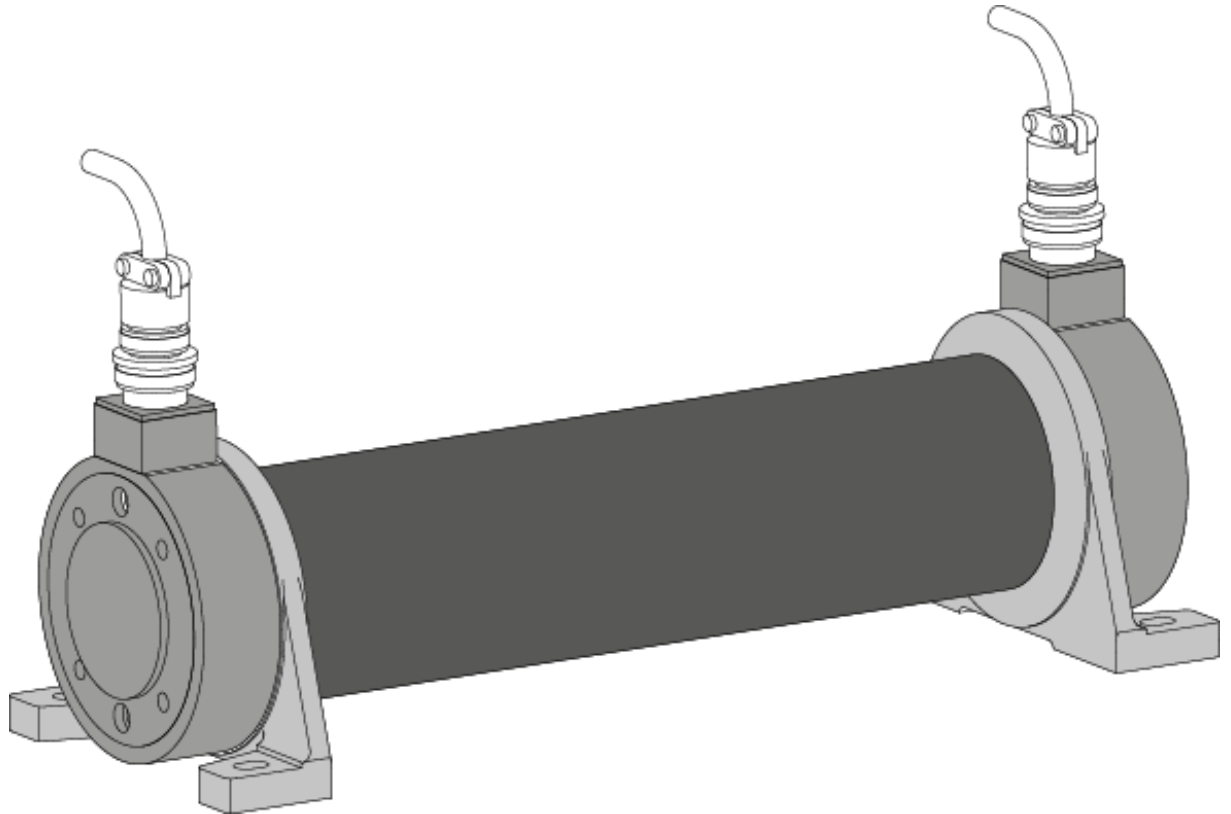

**Figure 9: bracket installation outside**

- Slide the brackets onto the roll
- The force sensors are mounted to the roll as described earlier
- The brackets are mounted to the force sensors with 4 screws each
- The completely assembly is installed on the machine frame.

## 4.8 Electrical connections

Connection between force sensor and measuring amplifier is realized by means of a 2 x 4 x 2 x 0.75mm<sup>2</sup> shielded, twisted-pair cable. The cable must be installed separate from power lines.

Connect the shielding only on the side of the measuring amplifier.

The signals –excitation have to be connected together.

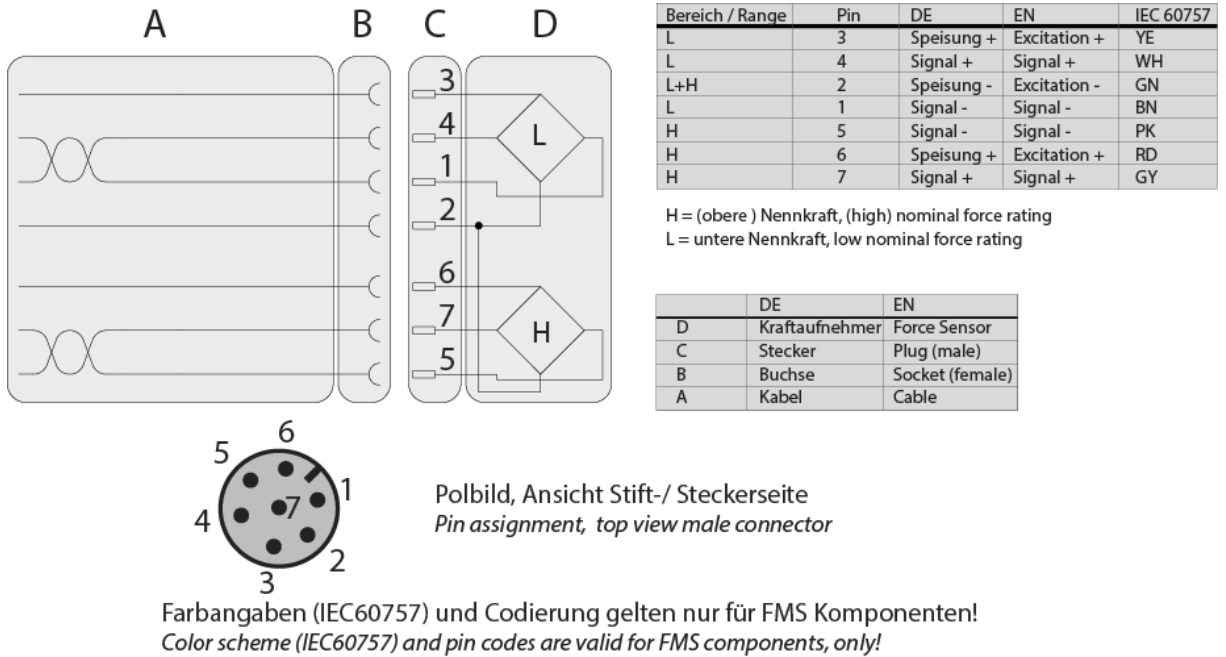

Figure 10: pin assignment Amphenol 7-pole  
Pin\_Assignment\_Sensorkabel\_Farben\_Stecker.ai

### 4.8.1 Connection to dual-channel measuring amplifier

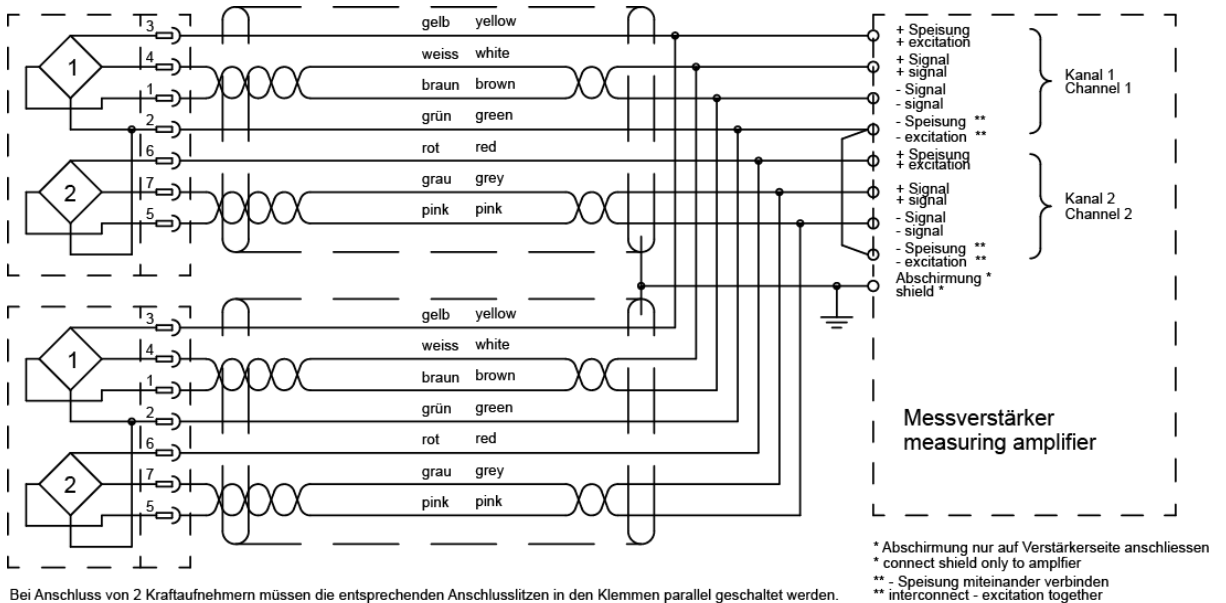

Figure 11: dual-channel amplifier

LMGZD\_BA\_Manual.ai

### 4.8.2 Connection to two single channel measuring amplifiers

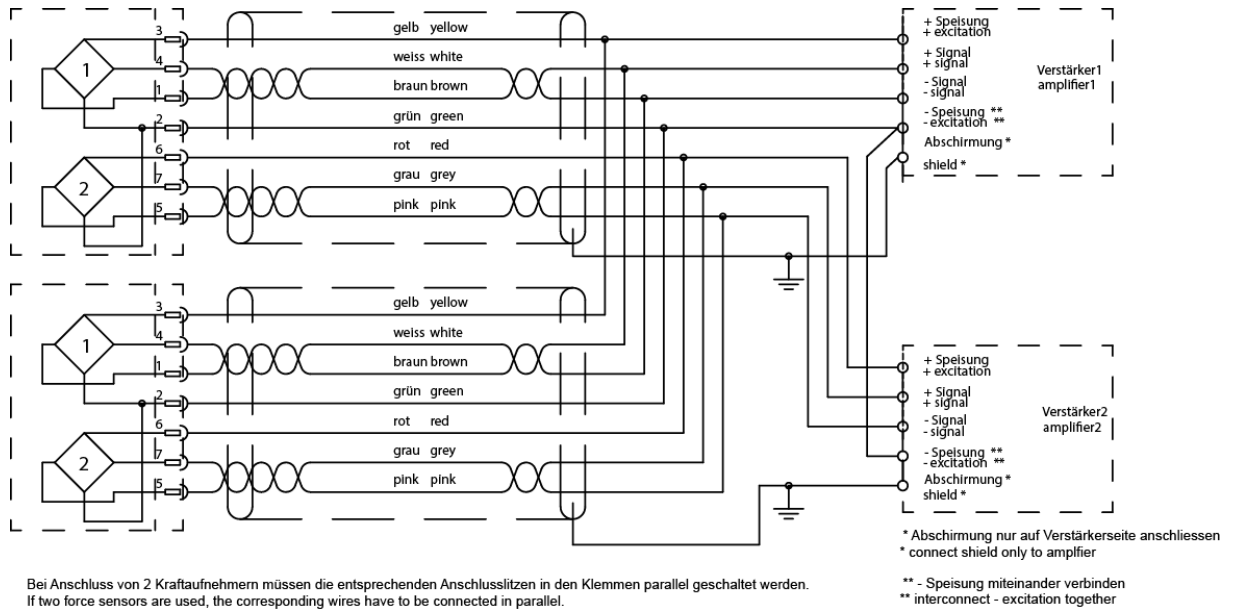

Figure 12: single channel amplifier

LMGZD\_BA\_Manual.ai



## 5 Maintenance

FMS force sensors are maintenance free. Depending on the applied type of bearing, it may be necessary to re-lubricate them.

Therefore, the closed covers have to be removed.

If the force sensors are installed inside, the complete roll has to be removed from the machine to access the closed covers.

## 6 Technical data

Technical data	
Sensitivity	1.8 mV/ V
Tolerance of sensitivity	< $\pm 0.2$ %
Accuracy class	$\pm 0.3$ % ( $F_{Nom}$ )
Measuring range	500:1
Temperature coefficient	$\pm 0.1$ % / 10 K
Temperature range	-10 bis +60 °C
Protection class	IP42
Input resistance	350 $\Omega$
Power supply	1 bis 7 VDC
Overload protection	10-times nominal force
Max. axial load	15 % of nominal force
Material	Stainless steel
Electrical connection	Male flange connector Amphenol, 7-pole

Table 4: technical data

# 7 Dimensions

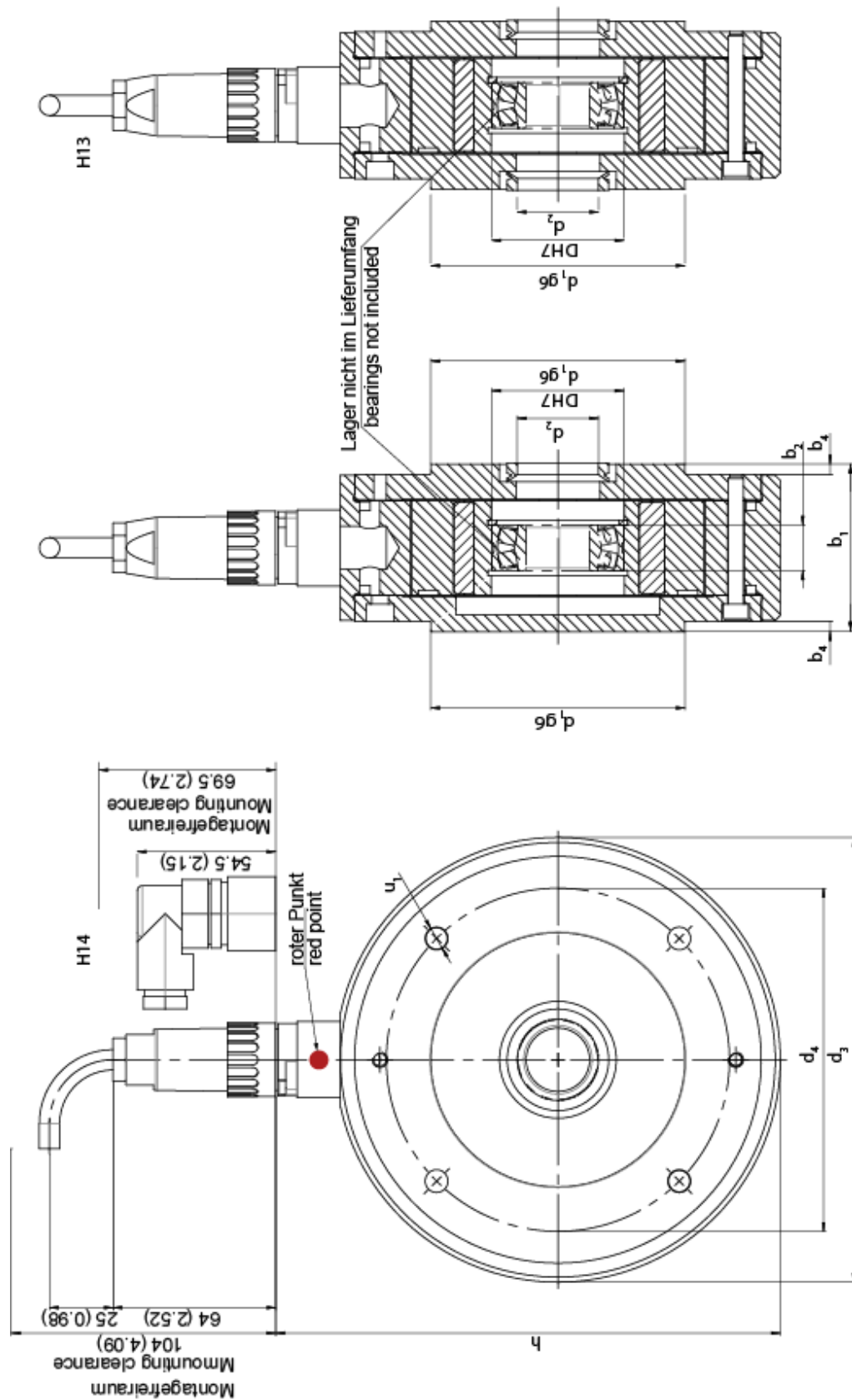

Figure 13: dimensions

LMGZD\_BA\_Manual.ai

<b>LMGZD-Baureihe : Abmessungen</b>										
Baugröße Typ	D mm (in.)	d1 mm (in.)	d2 mm (in.)	d3 mm (in.)	d4 mm (in.)	b1 mm (in.)	b2 mm (in.)	b4 mm (in.)	h mm (in.)	u mm (in.)
LMGZD202	35 (1.38)	70 (2.76)	20 (0.79)	125 (4.92)	95 (3.74)	43.5 (1.71)	14 (0.55)	4 (0.16)	157 (6.18)	6.6 (0.26)
LMGZD205	52 (2.05)	100 (3.94)	31 (1.22)	175 (6.89)	135 (5.31)	66 (2.60)	18 (0.71)	4 (0.16)	207 (8.15)	9 (0.35)
LMGZD307	80 (3.15)	130 (5.12)	44 (1.73)	225 (8.86)	175 (6.89)	76 (2.99)	23 (0.91)	4 (0.16)	258 (10.16)	11 (0.43)

**Figure 14: dimensions**

**Datesheet\_LMGZD\_series.indd**



**FMS Force Measuring Systems AG**  
 Aspstrasse 6  
 8154 Oberglatt (Switzerland)  
 Tel. 0041 1 852 80 80  
 Fax 0041 1 850 60 06  
 info@fms-technology.com  
 www.fms-technology.com

**FMS USA, Inc.**  
 2155 Stonington Avenue Suite 119  
 Hoffman Estates., IL 60169 (USA)  
 Tel. +1 847 519 4400  
 Fax +1 847 519 4401  
 fmsusa@fms-technology.com

**FMS (UK)**  
 Aspstrasse 6  
 8154 Oberglatt (Switzerland)  
 Tel. +44 (0)1767 221 303  
 fmsuk@fms-technology.com

**FMS (Italy)**  
 Aspstrasse 6  
 8154 Oberglatt (Switzerland)  
 Tel. +39 02 39487035  
 fmsit@fms-technology.com