

Montagefreiraum  
mounting clearance  
38 [1.5]

Montagefreiraum  
mounting clearance  
26 [1.02]

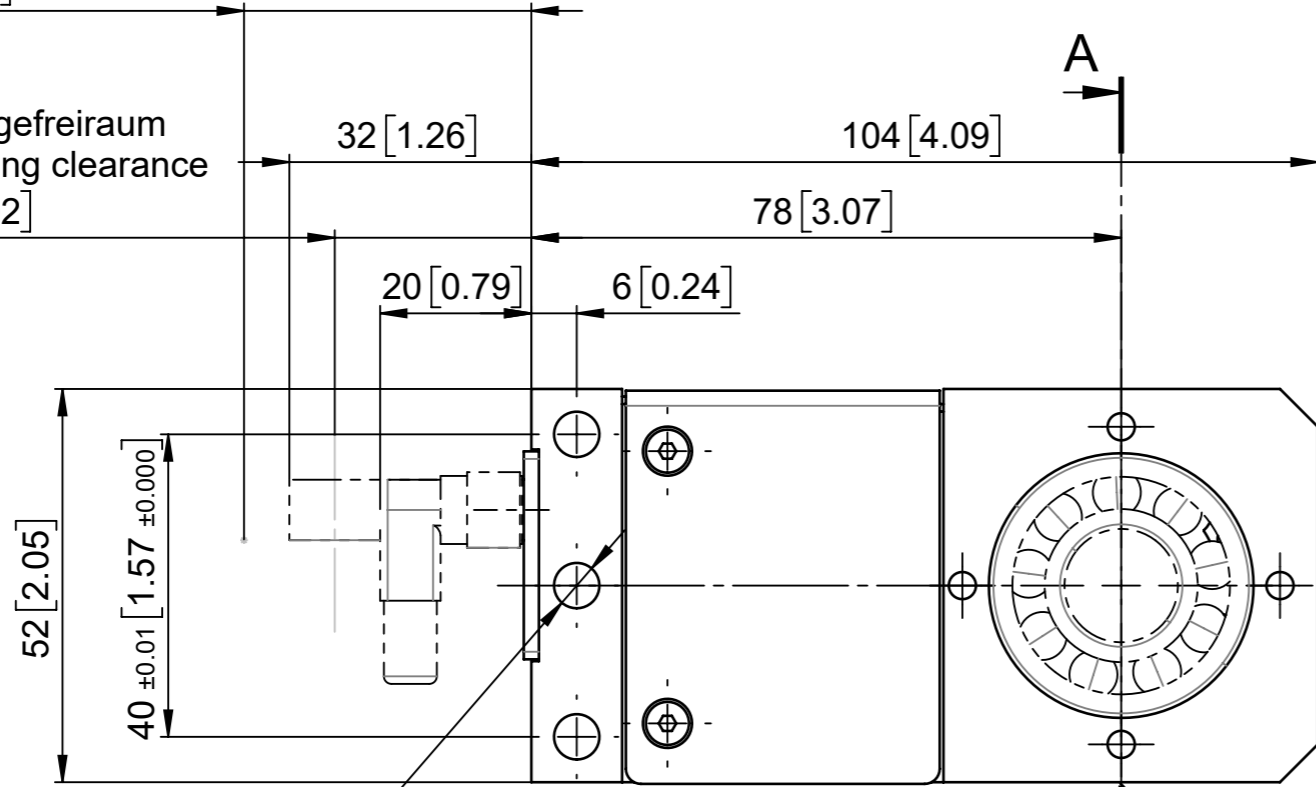

$\varnothing 6 H7 [0.24 H7] (3x)$

roter Punkt  
red point

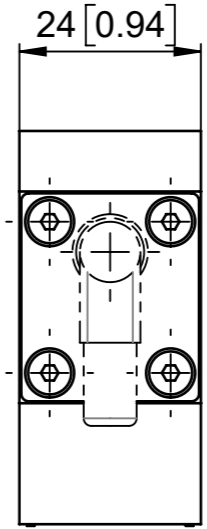

A-A

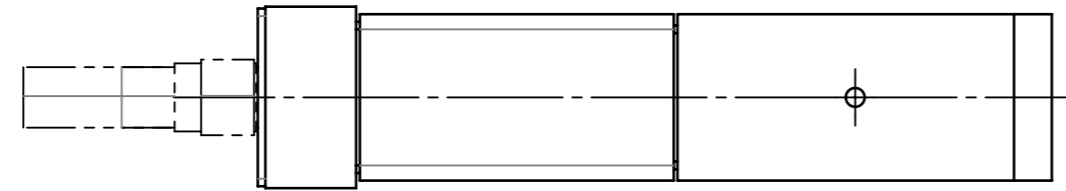
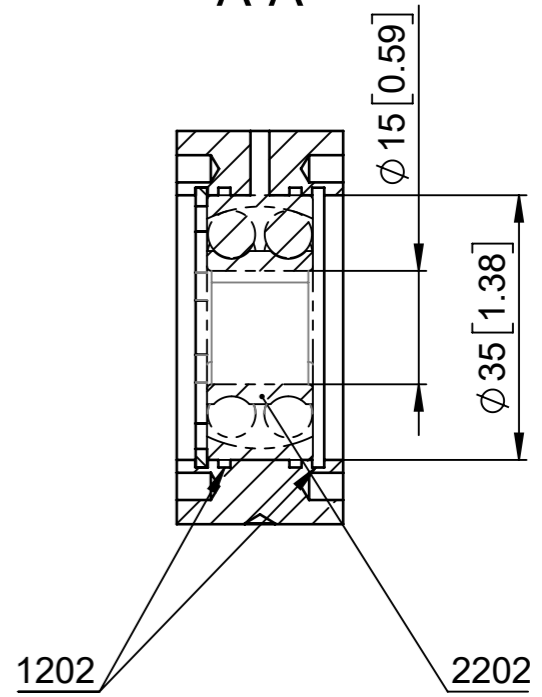

Änderungen	A	12.12.2019	DL	mehr Details zeigen	Erstellt	03.10.2017	K.Vladar	Massstab 1:1	
	-			Erstausgabe	Geprüft				
					Freigegeben	12.12.2019	D.Lenz		
Ohne sep. Stückliste <input type="checkbox"/>					Projekt		Status		Freigegeben
Sep. Stückliste gleicher Nr. <input type="checkbox"/>					Migration17		Ursprung		-
Sep. Stückliste anderer Nr. <input type="checkbox"/>					Artikel-Nr. 50001469		Ersatz für		-
Benennung					F202.		Zeichnungs-Nr.		080730-3
F202							Revision		A