



Operation Manual RTM MP Plus

EMGZ482T.PLUS.MP.W.24VDC
EMGZ482R.MP and EMGZ443MP.R

**Multi-Purpose Radio Transmission Tension Monitoring System
with Encoder Signal Evaluation**

Document Version 1.4 01/2019 NS
Firmware Version V 3.03

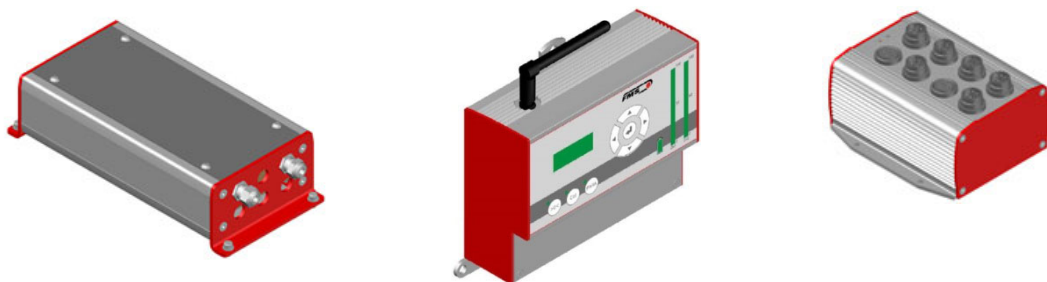

Diese Bedienungsanleitung ist auch in Deutsch erhältlich.
Bitte kontaktieren Sie Ihren nächstgelegenen FMS Vertreter.

Table of Contents

1	Safety Instructions.....	3
1.1	Description conditions	3
1.2	List of Safety Instructions	4
2	System Description.....	4
2.1	Functional Description RTM MP System	4
2.2	Main System Components	6
3	Certifications and Compliancy	7
4	Installation and Wiring.....	9
4.1	Area of Machine Rotation	9
4.2	Static installation of force sensor	9
4.3	Installation of Force Sensors on a Rotating Machine Part	9
4.4	Mounting and Wiring the Electronic Components	10
4.5	Mounting and Wiring the EMGZ482T.PLUS.MP.W.24VDC	11
4.6	Components on the Static Part of the Machine	12
4.7	In- and Output Schematics RTM MP	13
4.8	Wiring the Receiver EMGZ482R.MP	15
4.9	Connectors EMGZ443MP.R (static machine part)	16
5	Configuration of the RTM MP System	18
5.1	RTM MP Quick Start	18
5.2	Description of the Operating Panel EMGZ482R.MP	18
5.3	Offset Compensation Procedure	19
5.4	Calibration Methods	20
5.5	Calibration Procedure	20
5.6	Relay Output for Lost Communication	20
6	Mechanical Dimensions.....	21
7	Trouble Shooting.....	22
8	Technical Data	23

1 Safety Instructions

All safety related regulations, local codes and instructions that appear in the manual or on equipment must be observed to ensure personal safety and to prevent damage to the equipment connected to it. If equipment is used in a manner not specified by the manufacturer, the protection provided by the equipment may be impaired. Do not stress the equipment over the specification limits neither during assembly nor operation. To do so can be potentially harmful to persons or equipment in the event of a fault to the equipment.

1.1 Description conditions

a) Danger of health injury or loss of life



Danger

This symbol refers to high risk for persons to get health injury or loss life. It has to be followed strictly.

b) Risk of damage of machines



Caution

This symbol refers to information, that if ignored, could cause heavy mechanical damage. This warning has to be followed absolutely.

c) Note for proper function



Note

This symbol refers to an important information about proper use. If not followed, malfunction can be the result.

1.2 List of Safety Instructions

- ⚠** *Changes or modifications made to this equipment not expressly approved by (manufacturer name) may void the FCC authorization to operate this equipment.*
- ⚠** *This device complies with Part 15 of the FCC Rules and with Industry Canada licence-exempt RSS standard(s). Operation is subject to the following two conditions:
(1) this device may not cause harmful interference, and
(2) this device must accept any interference received, including interference that may cause undesired operation.*
- ⚠** *Radiofrequency radiation exposure Information.
This equipment complies with FCC radiation exposure limits set forth for an uncontrolled environment. This equipment should be installed and operated with minimum distance of 20 cm between the radiator and your body: This transmitter must not be co-located or operating in conjunction with any other antenna or transmitter.*
- ⚠** *It is of paramount importance to compensate the centrifugal forces caused by the rotating base plate of the stranding machine. The measuring results will be wrong, if this rule is broken.*
- ⚠** *Proper function of the FMS RTM MP System can only be guaranteed with the recommended application of the components. Other arrangements can cause malfunctions. Therefore, the installation instructions on the following pages must be followed.*
- ⚠** *Local installation regulations are to preserve safety of electric equipment. They are not taken into consideration by this operating manual. However, they have to be followed strictly.*
- ⚠** *The shield should be connected only to the electronic unit. On the force sensor side the shield should stay open.*
- ⚠** *Bad earth ground connection may cause electric shock to persons, malfunction of the total system or damage of the electronic unit! It is vital to ensure that proper earth connection is done.*
- ⚠** *The sensor cables must be installed separate from power lines.*

2 System Description

2.1 Functional Description RTM MP System

FMS' RTM MP System has been developed to measure and evaluate all kind of production relevant parameters in Wire Processing Machinery (especially in Bow Type Stranding Machines). The System consists of a combined transmitter-decoding unit, a receiver and further decoding modules in the receiver part. RTM MP uses two force sensors for the measurement of the wire tension. Encoder signals and wire tension

values are captured, conditioned and sent over a 2.4 GHz wireless link to the receiver unit EMGZ 48R.MP. Further processing of the encoder signals takes place in the decoding module EMGZ443R.MP Here all relevant data for the actuator drivers or the machine control is available. A fully equipped system can handle up to 16 digital inputs and outputs, two force measuring rollers and 2 encoder channels. The later can e.g. be used for close loop control of drives and the control of the traverse guide in individual bobbins.

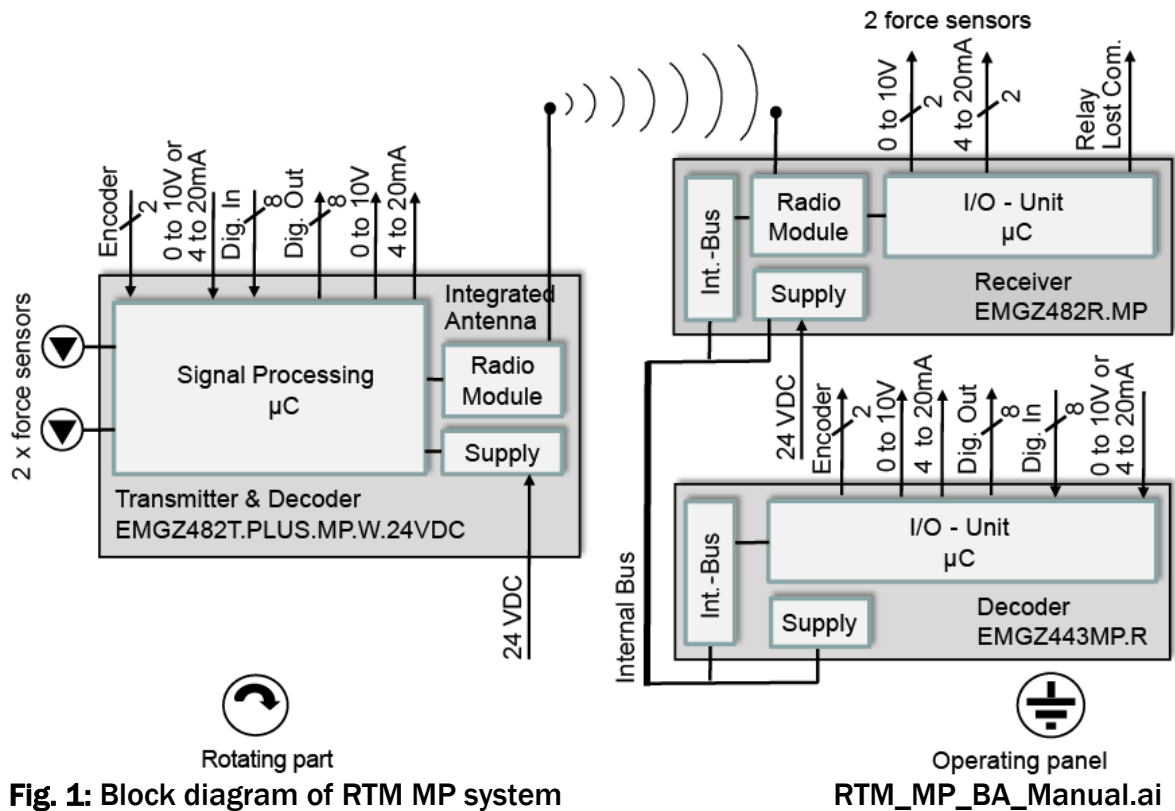

2.2 Main System Components



RMGZ Force Measuring Rollers

- Measures the wire tension
- Converts the tension values in an electrical signal



EMGZ482T.PLUS.MP.W.24VDC

- Amplification and conditioning of the electrical signals
- Wireless transmission (antenna is integrated on front plate)
- Power supply 24 VDC via slip rings
- I/O Configuration:
 - 1x Analogue output 0...10V or 4...20mA
 - 1x Analogue input 0...10V or 4...20mA
 - 2x Encoder Inputs
 - 8x Dig. outputs
 - 8x Dig. inputs

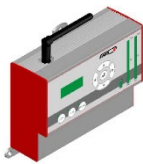

EMGZ482R.MP

- Wireless reception of tension data
- Offset compensation
- Bus connection to EMGZ443MP.R
- Data transfer to EMGZ443MP.R and PLC.

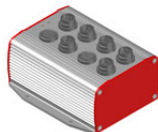

EMGZ443MP.R Decoding Module receiver Side

- Expansion of I/O Configuration by:
 - 1x Analogue output 0...10V or 4...20mA
 - 1x Analogue input 0...10V or 4...20mA
 - 2x Encoder outputs
 - 8x Dig. outputs
 - 8x Dig. inputs

3 Certifications and Compliancy

This equipment has been tested and found to comply with following rules:

ETSI Radio Certification	
Magnitude of Test (Coverage)	Article 3.2 of Directive 1999/5/EC (R&TTE Directive)
Certification	ETSI EN 300 440-2 V1.5.1 (2009-03) ETSI EN 300 440-1 V1.3.1 (2009-03)
ETSI EMC Certification	
Magnitude of Test (Coverage)	ECM-Test according to 98/37/EC and 2004/108/EC harmonized
Emission and Immunity Test	ETSI EN 489-3 EN 61326-1
FCC Certification	
Magnitude of Test	Class A digital device, pursuant to Part 15 of the FCC Rules
Certification	FCC Registration #: 0020311882



Note

This equipment has been tested and found to comply with the limits for a Class A digital device, pursuant to Part 15 of the FCC Rules. These limits are designed to provide reasonable protection against harmful interference when the equipment is operated in a commercial environment. This equipment generates, uses, and can radiate radio frequency energy and, if not installed and used in accordance with the instruction manual, may cause harmful interference to radio communications. Operation of this equipment in a residential area is likely to cause harmful interference in which case the user will be required to correct the interference at his own expense.

**Caution**

Changes or modifications made to this equipment not expressly approved by (manufacturer name) may void the FCC authorization to operate this equipment.

**Caution**

This device complies with Part 15 of the FCC Rules and with Industry Canada licence-exempt RSS standard(s). Operation is subject to the following two conditions:

- (1) this device may not cause harmful interference, and***
- (2) this device must accept any interference received, including interference that may cause undesired operation***

**Caution**

Radiofrequency radiation exposure Information.

This equipment complies with FCC radiation exposure limits set forth for an uncontrolled environment. This equipment should be installed and operated with minimum distance of 20 cm between the radiator and your body:

This transmitter must not be co-located or operating in conjunction with any other antenna or transmitter.

4 Installation and Wiring

4.1 Area of Machine Rotation

Following RTM MP components are installed either on the rotating part of the machine or in the area of machine rotation:

- Transmitter EMGZ482T.MP.PLUS.W.24VDC
- RMGZ Force Measuring Rollers

4.2 Static installation of force sensor

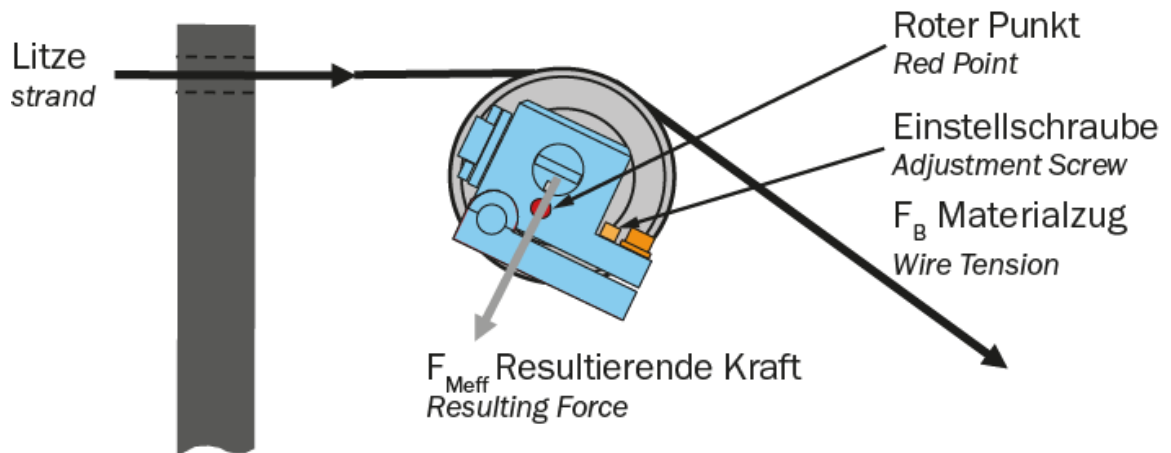

Fig. 2: RMGZ Red Point alignment on static machine parts
RTM_X42_Red_Point_Allignment_BA_Manua.ai

The red point should always be aligned in the direction of the resulting Force (see Fig. 2). For further mounting information please consult the respective installation manual of the sensor. The installation manual is always delivered together with the sensor.

4.3 Installation of Force Sensors on a Rotating Machine Part



Note

In rotating applications the force measuring sensors are mounted such that centrifugal forces are compensated. If using FMS RMGZ sensors, this can be achieved by turning the Red Point parallel to the rotation axis and in direction of the positive force component (refer to Fig. 3).



Note

The adjustment of the red point can be tested after offset compensation and calibration. If the reading of an unloaded load cell stays at zero regardless of the load cell position (e.g. at 12 o'clock or at 6 o'clock position), the red point is correctly aligned.

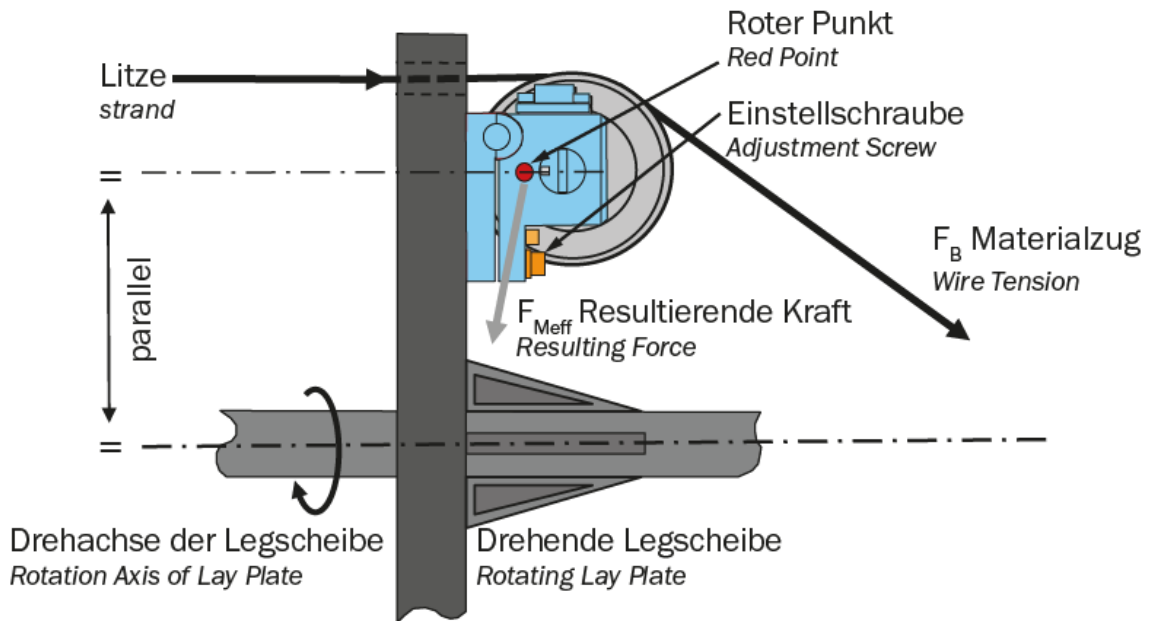

Fig. 3: RMGZ Red Point alignment on rotating machine parts
 RTM_X42_Red_Point_Allignment_BA_Manua.ai

⚠ Caution
It is of paramount importance to compensate the centrifugal forces caused by the rotating base plate of the stranding machine. The measuring results will be wrong, if this rule is broken.

4.4 Mounting and Wiring the Electronic Components

An RTM MP system is usually delivered complete with all its components and cables. The cables are prepared with connectors on both sides for easy assembly

⚠ Caution
Proper function of the FMS RTM MP system can only be guaranteed with the recommended application of the components. Other arrangements can cause malfunctions. Therefore, the installation instructions on the following pages must be followed.

⚠ Caution
Local installation regulations are to preserve safety of electric equipment. They are not taken into consideration by this operating manual. However, they have to be followed strictly.

4.5 Mounting and Wiring the EMGZ482T.PLUS.MP.W.24VDC

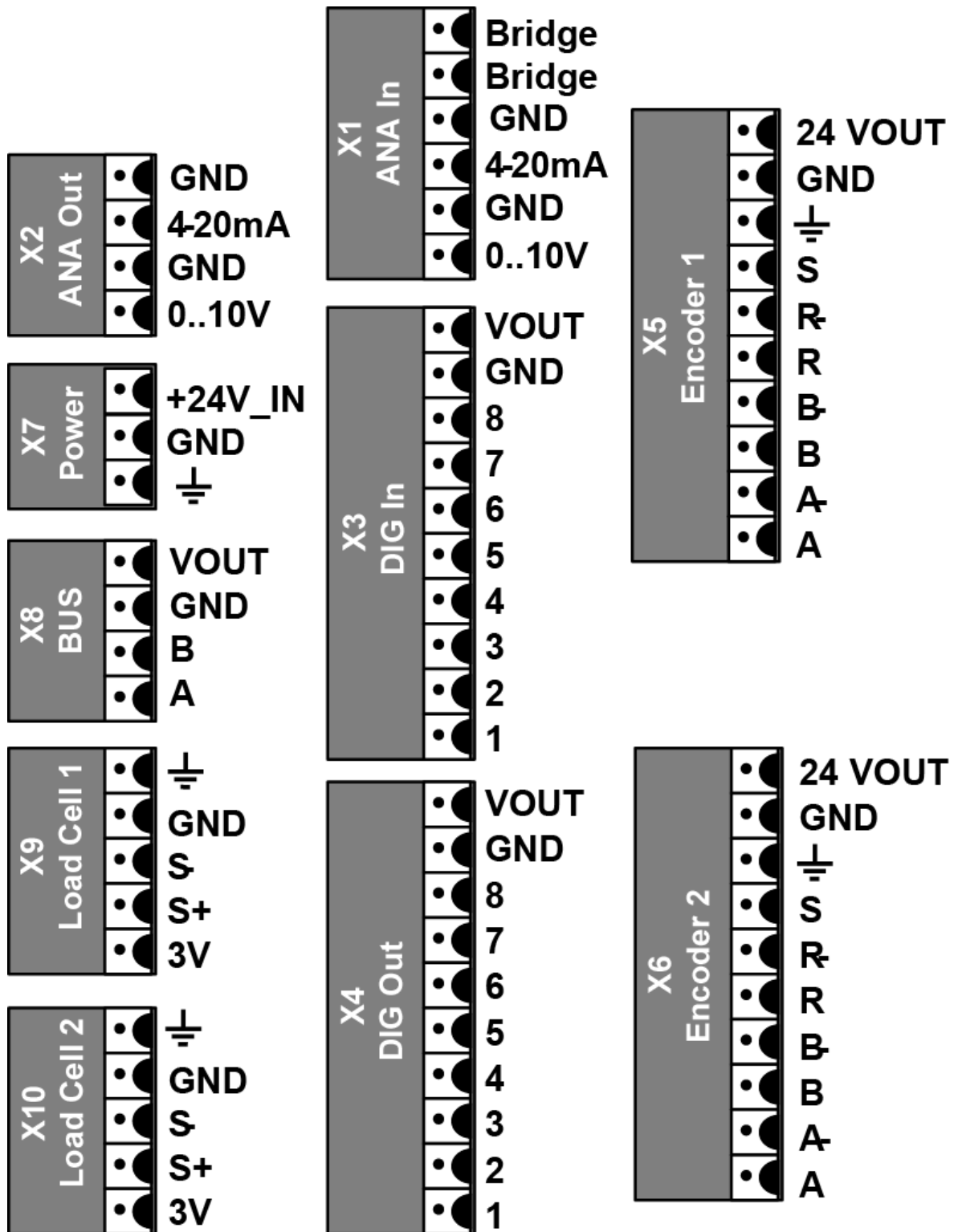

Fig. 4: Signal assignment EMGZ482T.PLUS.MP.W.24VDC
Press & Connect Terminals on Electronics Board

RTM_MP_BA_Manual.ai

4.6 Wiring of the transmitter EMGZ482T.PLUS.MP.W.24VDC

One or two force sensors can be connected to the RTM-Transmitter. It is favourably to mount the EMGZ482T.PLUS.MP.W.24VDC transmitter close to the RMGZ load cells to keep the signal cables short.

If no standard FMS cables are used, the connection between force sensors and transmitter must be wired with 2x2x0.25mm² [AWG 23] shielded twisted-pair cable.



Caution

The shield should be connected only to the electronic unit. On the force sensor side the shield should stay open.



Caution

Bad earth ground connection may cause electric shock to persons, malfunction of the total system or damage of the electronic unit! It is vital to ensure that proper earth connection is done.



Caution

The sensor cables must be installed separate from power lines.

4.7 Components on the Static Part of the Machine

Following RTM MP components are installed on the static part of the system:

- Receiver EMGZ482R.MP
- Multi-purpose Decoding Module EMGZ443MP.R
- Cables to PLC / Machine Control

4.8 In- and Output Schematics RTM MP

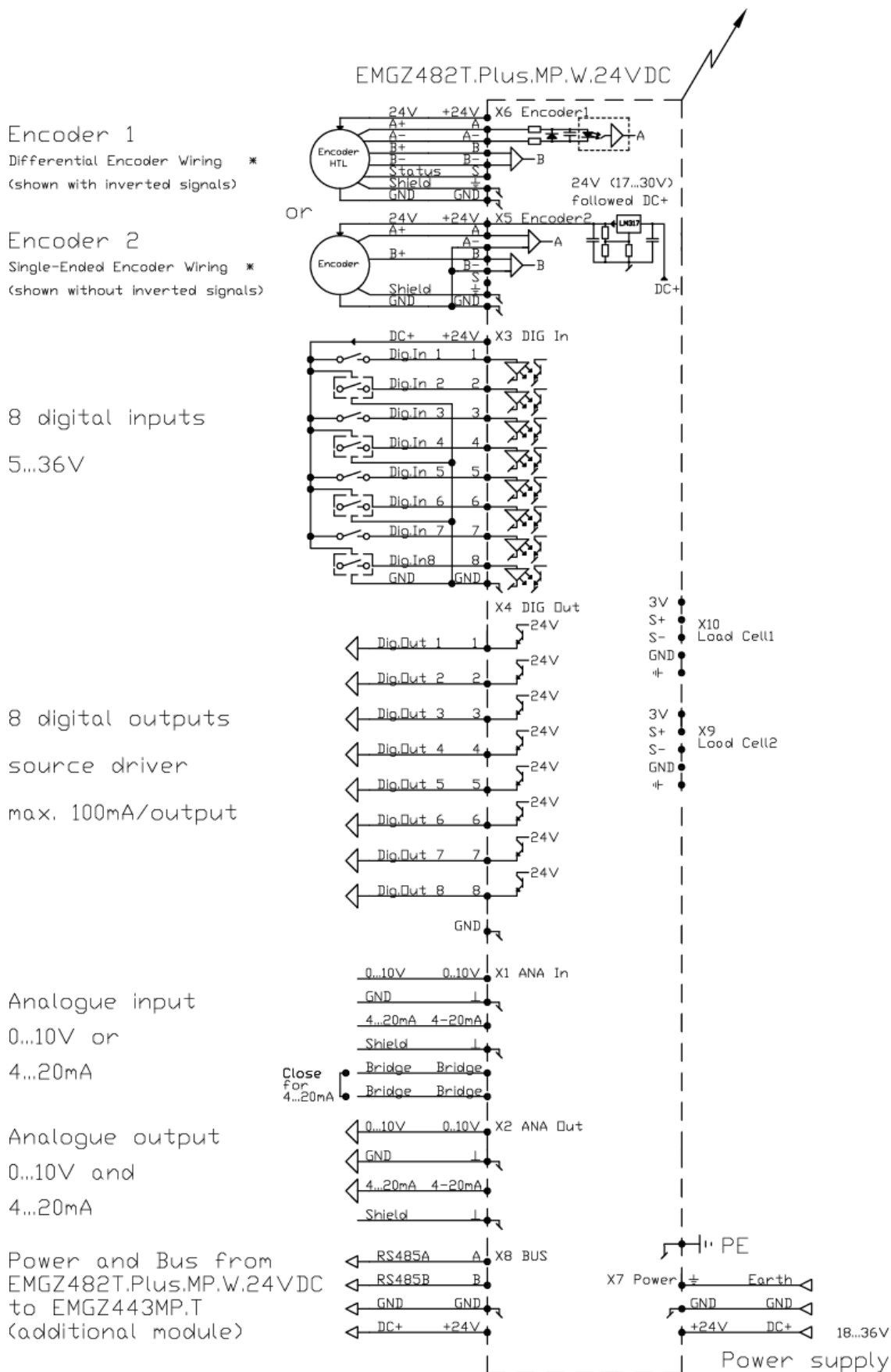

Fig. 5a: In / Output configuration EMGZ482.T.PLUS.MP.W.24VDC RTM_MP_BA_Manual.ai

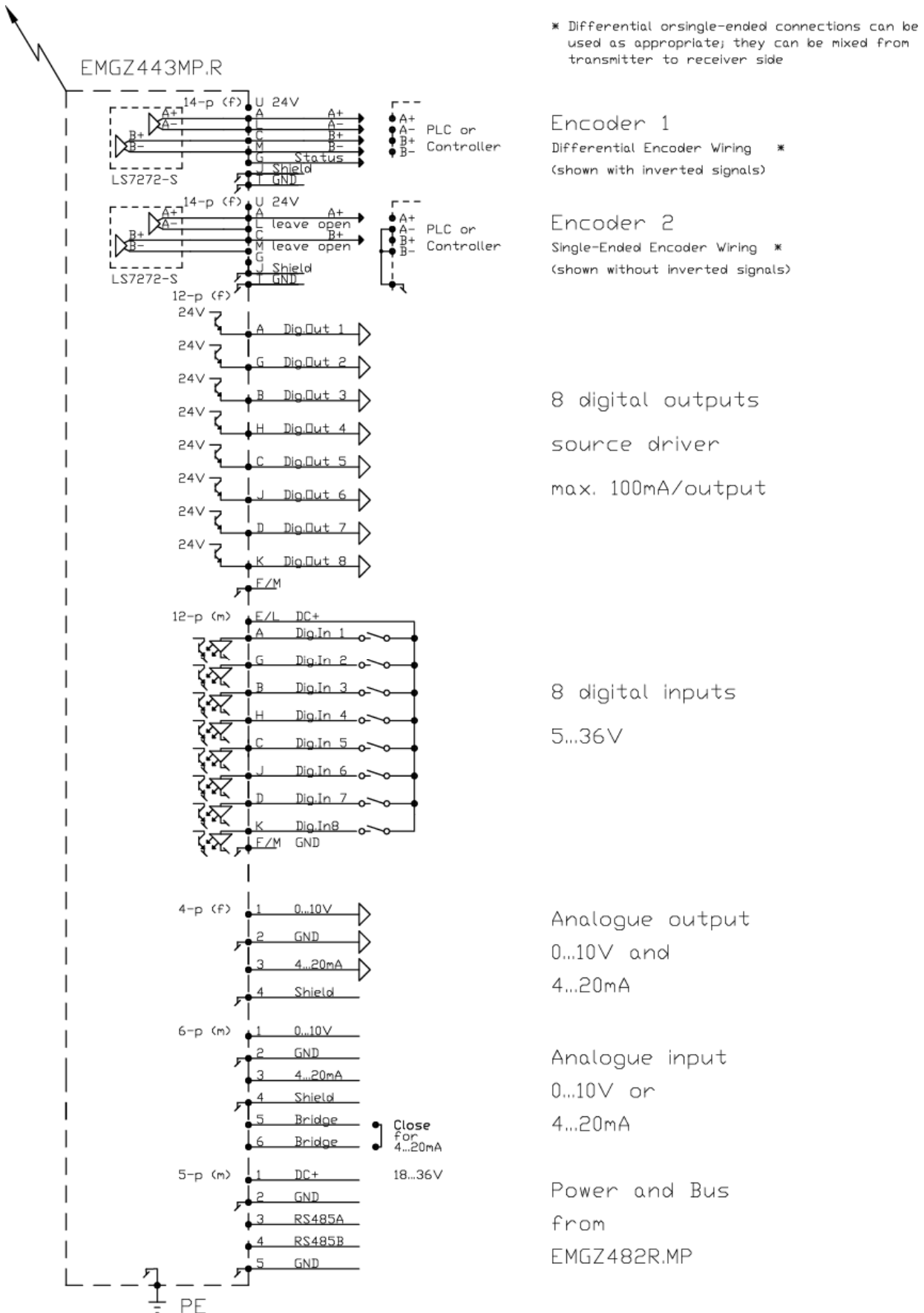

Fig. 5b: In / Output configuration EMGZ482.R.MP

4.9 Wiring the Receiver EMGZ482R.MP

EMGZ482R.MP receives the data captured by the RTM-transmitter and acts as an interface to a PLC or to a close-loop tension controller. Fig. 6 shows the pin assignment on the electronic board.

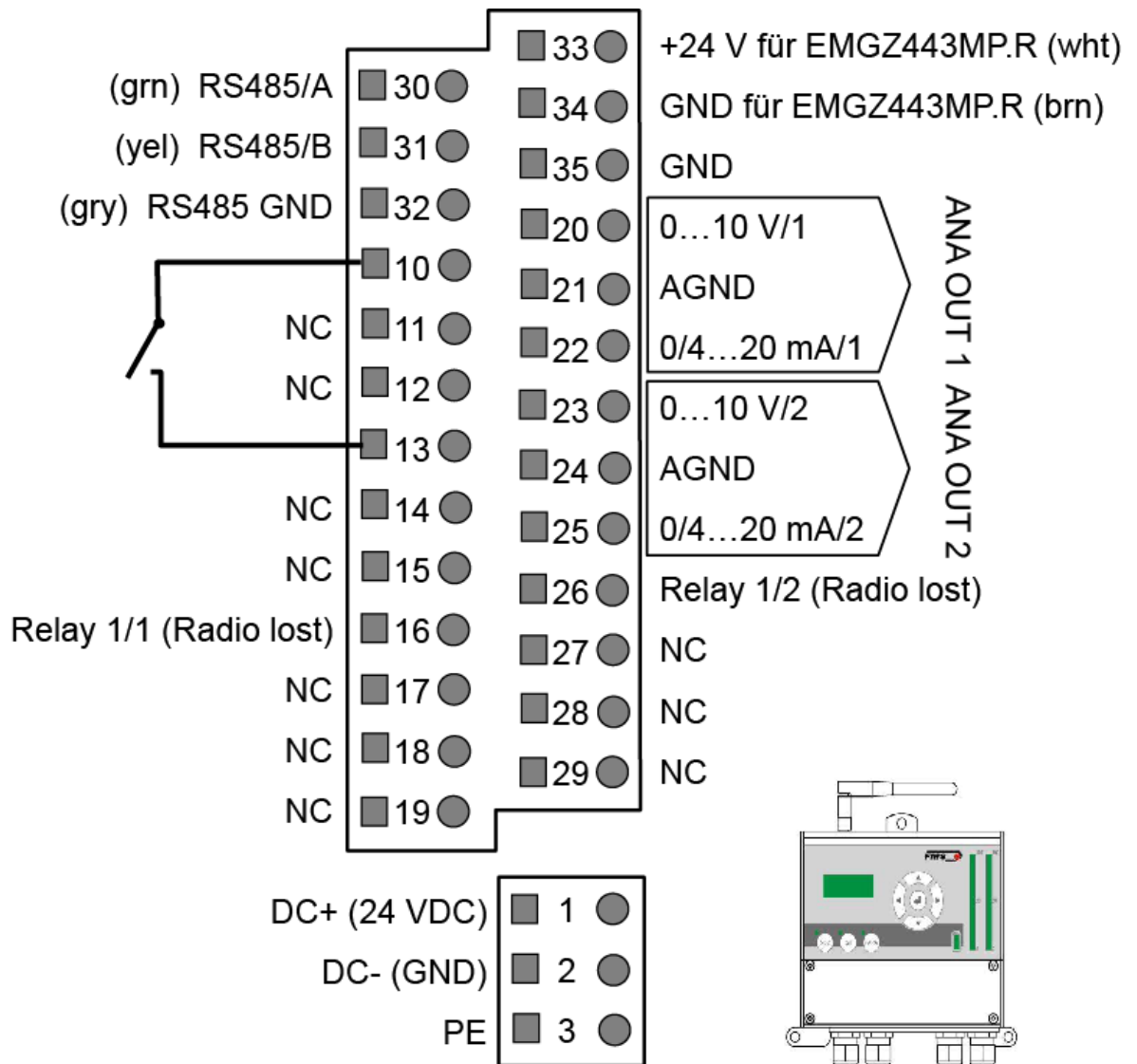
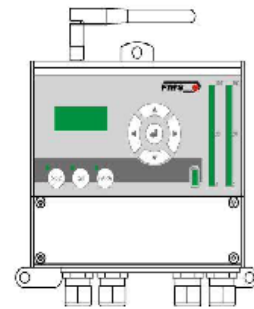

Fig. 6: Signal assignment EMGZ482R.MP on Electronic Board



RTM_MP_BA_Manual.ai

4.10 Connectors EMGZ443MP.R (static machine part)

The wiring diagrams below shows how the signals are wired to the connectors.

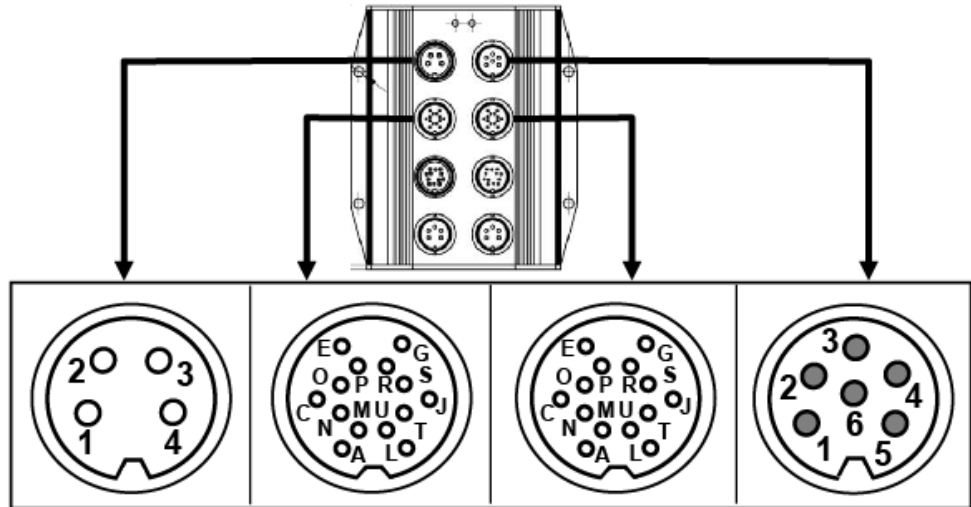

Pin	Farbe	Ana Out 4-p (f)	Enco 1 14-p (f)	Enco 2 14-p (f)	Ana In 6-p (m)	
1	A	white	0...10 VDC	A+	A+	0...10 VDC
2	C	brown	AGND	B+	B+	AGND
3	E	green	4...20 mA	Ref+ (inactive)	Ref+ (inactive)	4...20 mA
4	G	yellow	Shield	Status	Status	Shield
5	J	grey		Shield	Shield	Bridge
6	L	pink		A-	A-	Bridge
	M	blue		B-	B-	
	N			NC	NC	
	O			NC	NC	
	P			NC	NC	
	R			NC	NC	
	S	red		Ref- (inaktive)	Ref- (inactive)	
	T	black		GND	GND	
	U	purple		24 V ENC	24 V ENC	

Fig. 9: Signal assignment EMGZ443MP.R (1st part)
Connectors are shown form the mating side.

RTM_MP_BA_Manual.ai

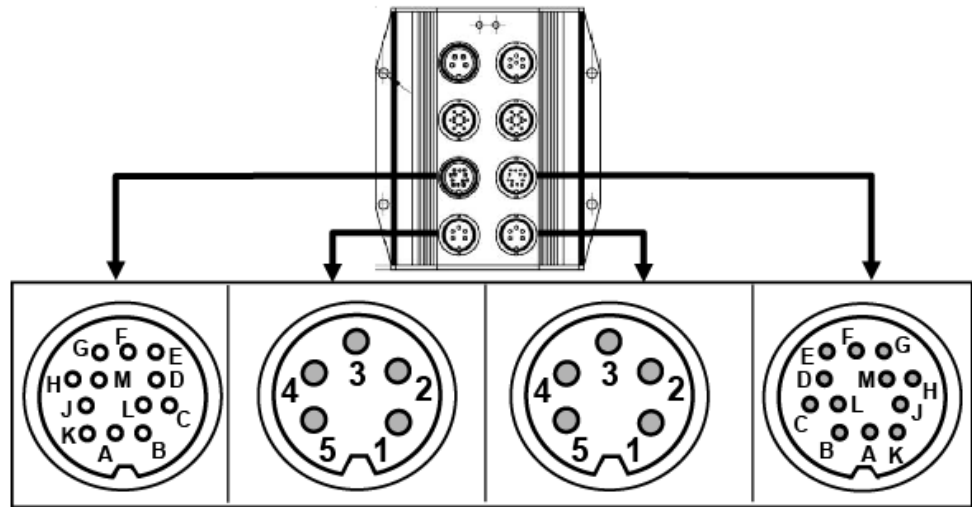

Pin	Farbe	Dig. Out 12-p (f)	Speisung&Bus 5-p (m)	Speisung&Bus 5-p (m)	Dig. In 12-p (m)	
1	A	white	Dig. Out 1	24 VDC	24 VDC	Dig. In 1
2	B	brown	Dig. Out 3	PGND	PGND	Dig. In 3
3	C	green	Dig. Out 5	RS485 A	RS485 A	Dig. In 5
4	D	yellow	Dig. Out 7	RS485 B	RS485 B	Dig. In 7
5	E	grey	24 VDC	GND	GND	24 VDC
	F	pink	PGND			PGND
	G	blue	Dig. Out 2			Dig. In 2
	H	red	Dig. Out 4			Dig. In 4
	J	black	Dig. Out 6			Dig. In 6
	K	purple	Dig. Out 8			Dig. In 8
	L	gry/pin	24 VDC			24 VDC
	M	red/blu	PGND			PGND

Fig. 10: Signal assignment EMGZ443MP.R (2nd part)) RTM_MP_BA_Manual.ai

Connectors are shown form the mating side.

5 Configuration of the RTM MP System

FMS delivers the RTM MP System with preset hardware components, installed software, a configured 2.4 GHz radio-link.

5.1 RTM MP Quick Start

1. After having mounted and wired the RTM MP system components on your machine power up the transmitter EMGZ482T.MP and receiver EMGZ482R.MP
2. The RTM MP system will establish the wireless radio link automatically. This initial process can take 5-10 sec.
3. After having achieved a stable radio link the LCD display on the EMGZ482.MP.R will show:



RTM443.MP
V3.03

4. The system is now ready and can be configured to over the operation panel on the EMGZ482MP.T.

5.2 Description of the Operating Panel EMGZ482R.MP

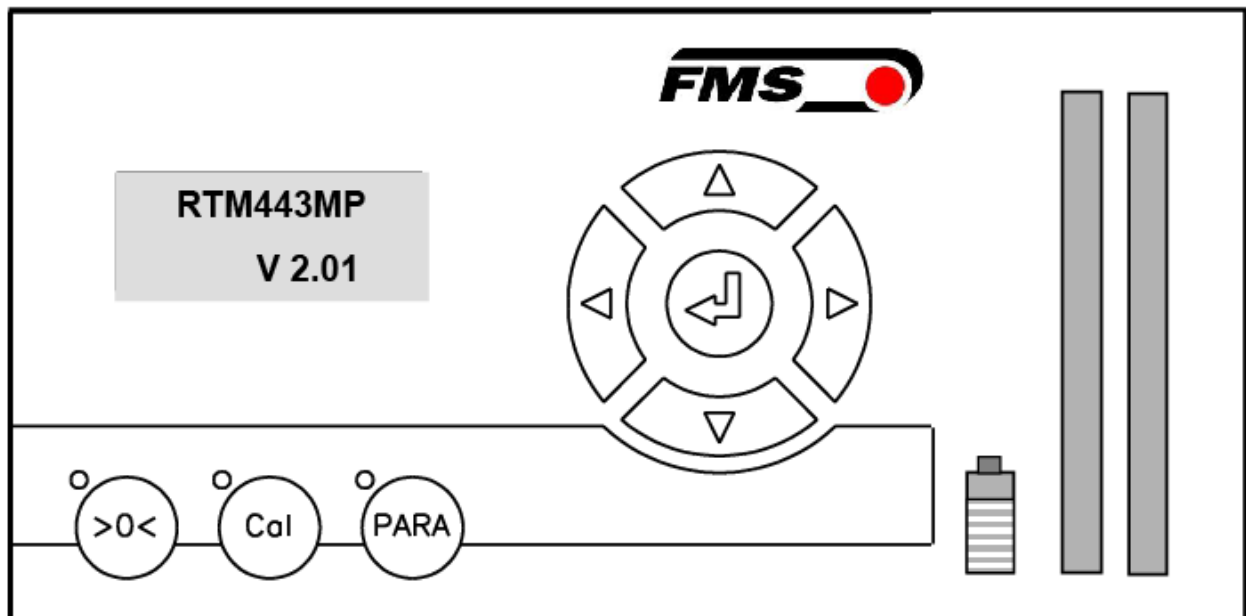

Fig. 11: View of the Operating Panel EMGZ482R.MP

RTM_MP_BA_Manual.ai

The battery symbol on the operation panel indicates the status of the supply voltage in the EMGZ482R.MP unit.

The keys on the operating panel of the EMGZ482R.MP version are all deactivated and have not their normal function as in the standard version.

Key	Key function during operation
	Key deactivated
	Key deactivated
	Key deactivated
	Key deactivated
	Keys deactivated
	Key deactivated
	Key deactivated

5.3 Offset Compensation Procedure

With the Offset Compensation one can compensate the roller weight of the sensor. This procedure is always performed before the calibration. The force measuring roller should not be loaded while the Offset Compensation is being done. The roller weight compensation is performed for both channels (sensor 1 and sensor 2).

Procedure:

1. Remove any wires that may apply a force to the roller.
2. Close a contact between terminal 10 and 13 on the EMGZ482R.MP (see Fig. 6). The switch time must be >100 ms.
3. This connection will perform the offset compensation on both force measuring rollers (sensor 1 and 2).

5.4 Calibration Methods

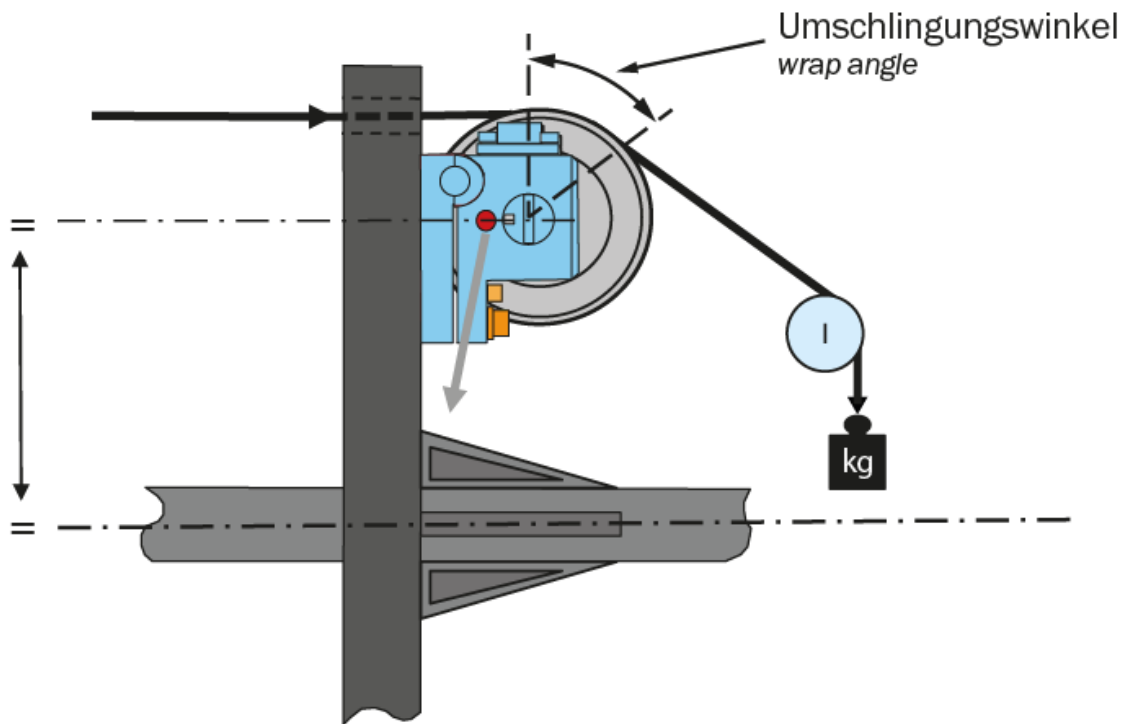

Fig. 12: Calibrating the measuring amplifier

RTM_MP_BA_Manual.ai

The Calibrating procedure (setting the Gain), adjusts the controller and force sensors so that the output gives you the actual tension value. There are two methods of calibrating the system. The first method uses a defined weight. The second method is based on a calculation method in conjunction with the FMS Calculator. This Calculator can be downloaded from the FMS web page. FMS recommends using the method with the weight (see Fig. 12) since it delivers the most accurate results.

5.5 Calibration Procedure

1. The calibration of the sensors must be performed with the PLC
2. Load a rope on the roller with the weight corresponding to your calibration force. The roller configuration must correspond to the real material path in the machine (wrap angle, distances between the rollers etc.).
3. The RTM MP-system will deliver tension raw data via the corresponding output
4. Enter the force data in your PLC and calibrate it matching your controlling needs.

5.6 Relay Output for Lost Communication

The relay output on the receiver EMGZ482.MP.R is deactivated, if the communication link between receiver and transmitter is lost. For the technical specification of the relay output see chapter 8 "Technical Data", Table EMGZ482R.MP.

6 Mechanical Dimensions

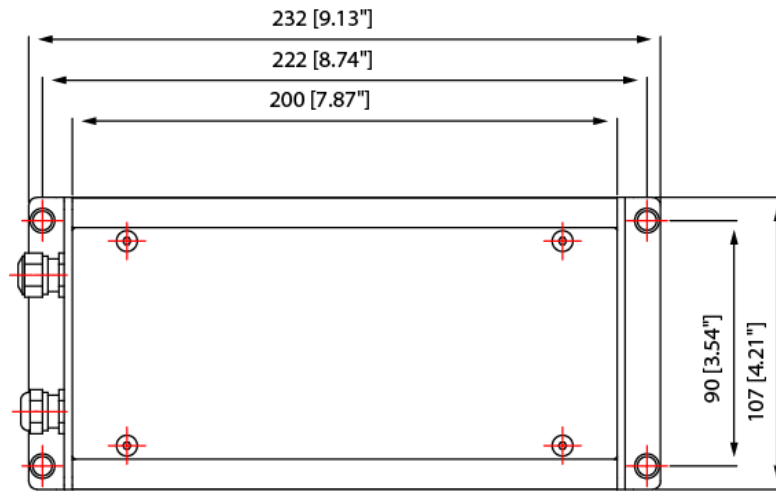
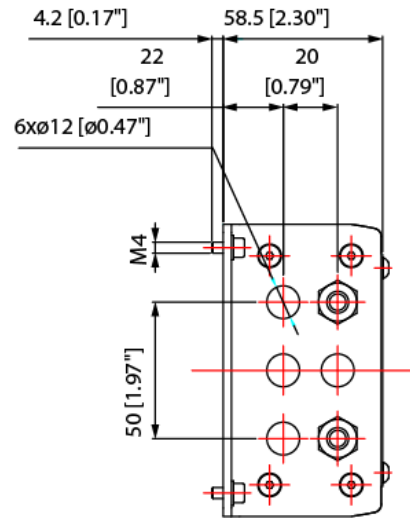

Fig. 13: Dimensions EMGZ482T.PLUS.MP.W.24VDC



RTM_MP_BA_Manual.ai

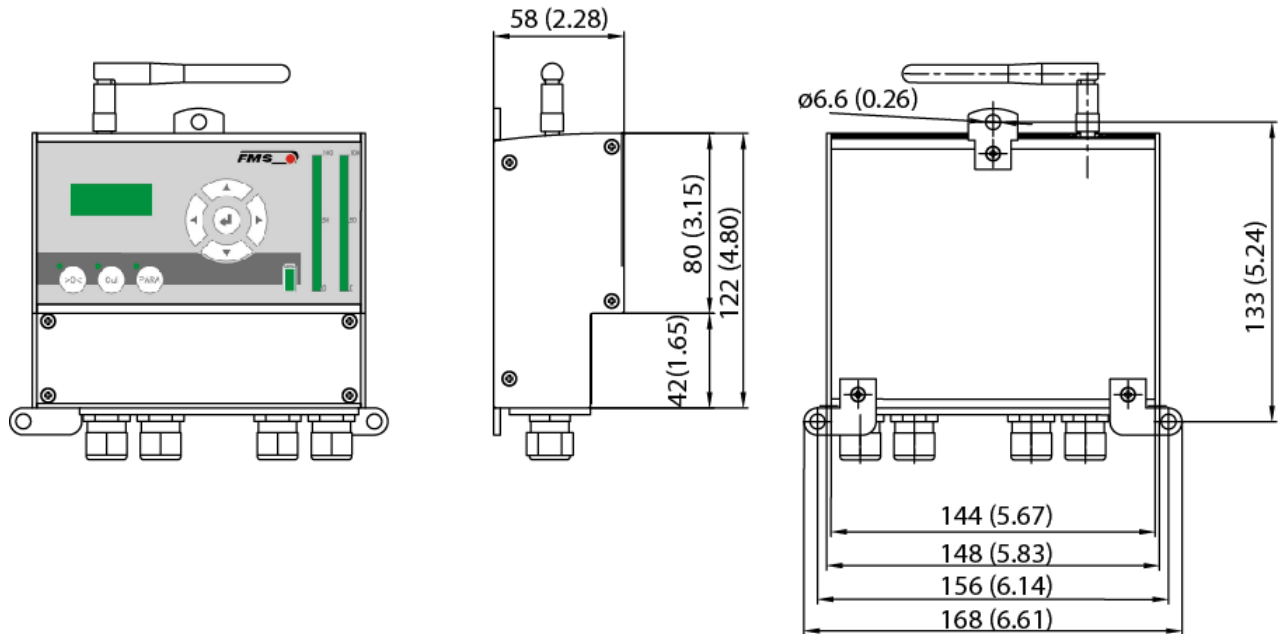

Fig. 14: Dimensions EMGZ482MP.R

RTM_MP_BA_Manual.ai

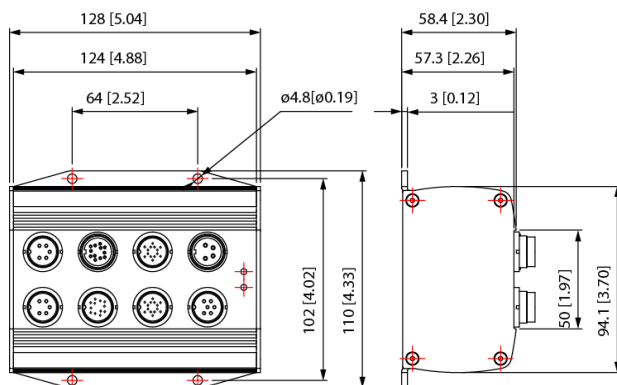

Fig. 15: Outline Drawing EMGZ443MP.R

RTM_MP_BA_Manual.ai

7 Trouble Shooting

Error	Cause	Corrective action
Relay output “Radio lost”	Radio link to EMGZ482R.MP is interrupted. Metallic objects between transmitter and receiver cause radio interferences	Check power supply to EMGZ482T.PLUS.MP.24VDC and EMGZ443MP.T Remove metallic objects from the radio path.
Feedback value doesn't correspond to the effective material tension	Sheave weight influences the measurement	Perform Offset compensation (see chapter 5.3)
Periodic oscillation on wire tension reading	Sheave weight influences the measurement or Alignment of red point is incorrect	Perform Offset compensation (see chapter 5.3) or See chapter 4.2 and 4.3. Align red point correspondingly and re-calibrate the system (chapters 5.4 and 5.5).
Feedback value doesn't correspond to the effective material tension	Alignment of red point is incorrect	See chapter 4.2 and 4.3. Align red point correspondingly and re-calibrate the system (chapters 5.4 and 5.5).
Very low tension values on PLC not corresponding to the effective material tension	Gain badly calculated or Wrongly calibrated	Re-calibrate the system (chapters 5.4 and 5.5) and write correct gain factor in PLC

8 Technical Data

EMGZ482T.PLUS.MP.W.24VDC	
Propagation delay	5.5 ms
Analogue output	0...10 VDC or 4...20mA
Analogue input	0...10 VDC or 4...20mA
Encoder inputs 1-2	2 channels max. 100kHz
Digital outputs 1-8	8 outputs; max. 100 mA / output (source)
Digital inputs 1-8	8 inputs 5...36 VDC
Force Measuring Channels 1-2	2 sensors with strain gauges @ 350 Ω (0...5.4 mV, max. 7.4 mV)
Measuring Error Force Sensor	<0.05% FS
Resolution A/D Converter	\pm 8192 Digit (14 Bit)
Sensor Supply	3.0 VDC, max. 20mA, high stability
Power Supply	24VDC via slip rings (18...36VDC / 10W max. 0.5A)
Wireless Interface	2.44 GHz
Power consumption	max. 18 W
Temperature Range	0...50 °C [32...122 °F]
Protection Class	IP52
Weight	0.75 kg [1.65 lbs]

EMGZ482R.MP	
Number of Channel	2 channels
Displays	LCD 2x 8 characters (8mm) Supply voltage indicator
Propagation delay	\leq 5ms
Resolution D/A Converter	0...4096 (12 Bit)
Wireless Interface	2.44 GHz
Analogue Output 1	0...10 VDC; min. 1.2k Ω or 4...20mA, max. 500 Ω
Analogue Output 2	0...10 VDC; min. 1.2k Ω or 4...20mA, max. 500 Ω
Relay Output	1 output (DC: 24V/0.5A/12W; AC:24V/0.5A/12VA)
Power Supply	24VDC (18...36VDC) / 10W (max. 0.5A)
Temperature Range	0...50 °C [32...122 °F]
Protection Class	IP52
Weight	0.65 kg [1.43 lbs]

EMGZ443MP.R	
Propagation delay	5.5 ms
Interface	RS485 Proprietary
Analogue output	0...10 VDC or 4...20mA
Analogue input	0...10 VDC or 4...20mA
Encoder inputs	2 channels max. 100kHz
Digital outputs	8 outputs; max. 100 mA / output (source)
Digital inputs	8 inputs 5...36 VDC
Power supply	24VDC (18...36VDC) max. 0.6A
Encoder power supply	HTL (15...30 VDC; max. 2 W)
Power consumption	max. 15W
Temperature range	0...+50 °C [32...122 °F]
Protection class	IP52
Weight	0.6 kg [1.32 lbs]



FMS Force Measuring Systems AG
 Aspstrasse 6
 8154 Oberglatt (Switzerland)
 Tel. 0041 1 852 80 80
 Fax 0041 1 850 60 06
 info@fms-technology.com
 www.fms-technology.com

FMS USA, Inc.
 2155 Stonington Avenue Suite 119
 Hoffman Estates, IL 60169 (USA)
 Tel. +1 847 519 4400
 Fax +1 847 519 4401
 fmsusa@fms-technology.com

FMS (UK)
 Aspstrasse 6
 8154 Oberglatt (Switzerland)
 Tel. +44 (0)1767 221 303
 fmsuk@fms-technology.com

FMS (Italy)
 Aspstrasse 6
 8154 Oberglatt (Switzerland)
 Tel. +39 02 39487035
 fmsit@fms-technology.com