

FMS Telemetry Systems

RTM X42 Modular Wire Tension Measuring for Tubular and Cage Type Stranders

- Continuous Measurement:**
 Important parameters under control, display of measuring values via optional RTM X42.CC Control Center or via your PLC
- Increased Product Quality and Efficiency:**
 Repeatable product quality, increased process safety and quality assurance, shorter downtimes, less scrap production
- Easy Retrofit, Reliable Data Transmission:**
 For cage and tubular type stranders of various designs and sizes, no need for slip rings
- Simple Integration into Existing Control Infrastructure:**
 Simple installation of the compact components, standardized Bus interface with high speed data transfer to your PLC

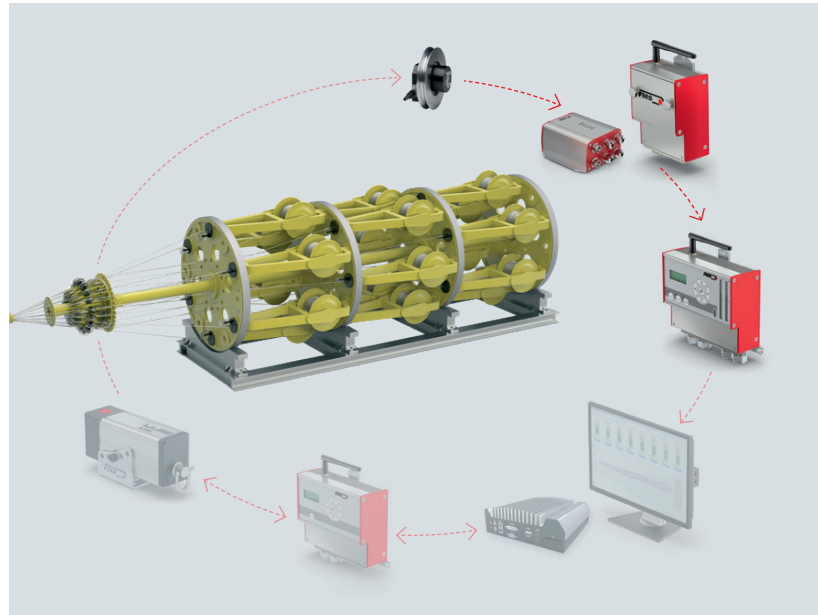

RTM X42

The RTM X42 Telemetry System provides the tension value of single strands or wires in cage or tubular type stranding machines. All personnel involved in the production environment gain easy access to these important process parameters.

The tension values can be displayed via the optional RTM X42.CC Control Center or via your PLC.

The standardized interface provides easy and quick connectivity to your existing machine, and an optional gateway can accommodate common protocols.

Many OEMs currently deliver their new machines with preinstalled RTM X42 systems, but due to the modular concept and the compact components, retrofitting our system to your existing machinery is also straightforward. Reliable radio transmission of the data and optional battery-packs make slip rings obsolete.

The typical RTM X42 system can handle the measurement of up to 42 individual wires or strands, but it is also possible to interconnect multiple telemetry systems to allow for an unlimited number of force sensors.

Functional Description

The RTM X42 system basically consists of a transmitter and a receiver. Depending on the number of force sensors, up to 10 extension modules could be utilized. The wire tension is captured with force sensors in the rotating part of the machine. Integrated electronics process and amplify the signal before it is reliably sent to the receiver that is located outside of the rotating part of the machine. The wired components of the RTM X42 system communicate via the Modbus TCP protocol, while an optional gateway provides translation to other bus protocols as needed to connect your PLC.

The visualization and the further processing of the measuring data can be carried out via the optional RTM X42.CC Control Center or via your PLC.

An extensive range of accessories enables you to gradually expand the functions of the RTM X42 system from tension measuring to integrated tension control with advanced analysis features.

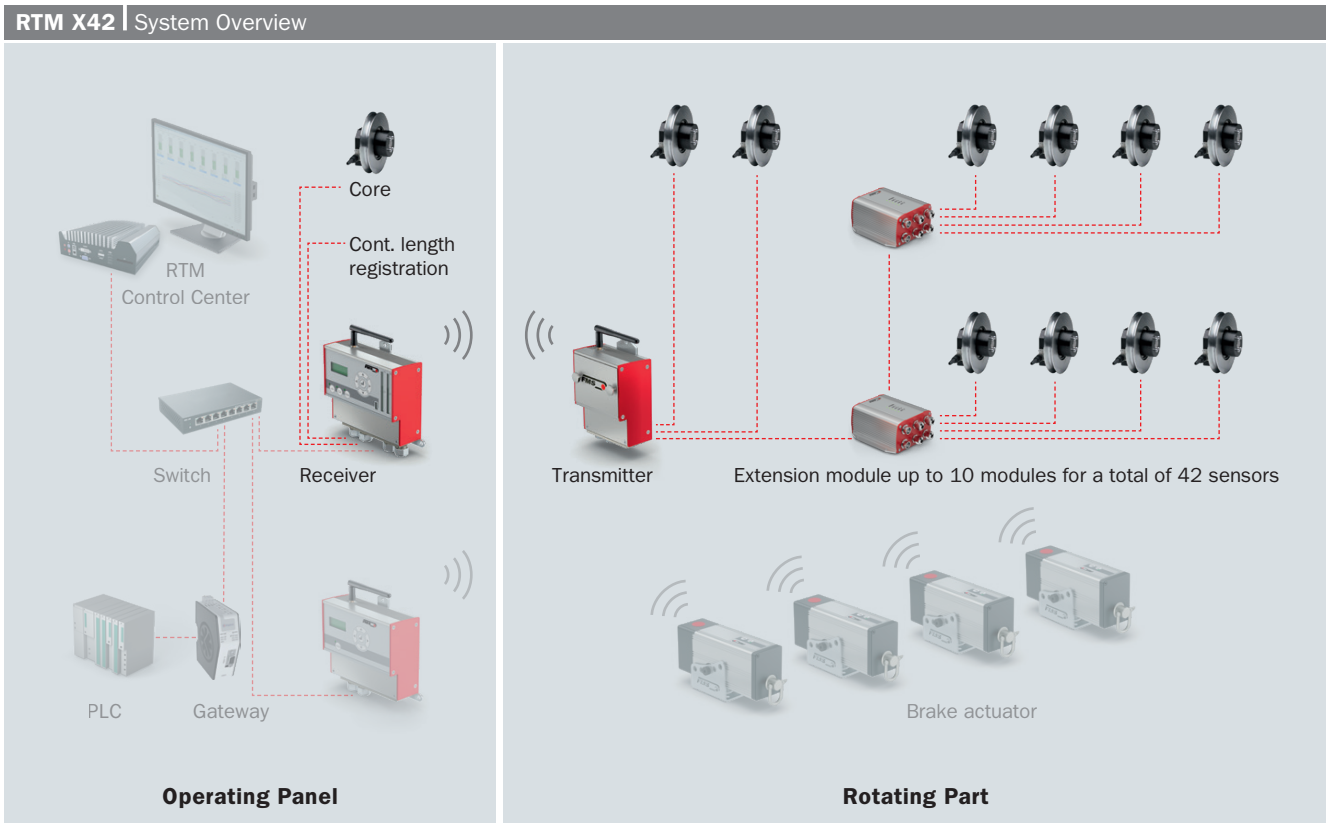

RTM X42 | Main Components

RTM X42 Receiver EMGZ482.R

Near the operating panel, receives the data from the transmitter



- Analog input for tension measurement of the core
- Analog input for continuous length registration
- 4 individually configurable relay outputs
- System configuration via web browser

RTM X42 Transmitter EMGZ482.T

On the rotating part of the machine, signal processing and radio module



- Compact housing for universal installation
- Robust, embedded design, protection against dust and dirt
- Safe operation even at high speed
- Reliable radio communication
- Long operating time with 20 Ah Li-Ion battery pack
- Autonomous battery charger

RTM X42 Extension EMGZ484.T

Interface and amplifier for four additional force sensors



- Robust and compact design, resistant to centrifugal force
- Plug & Play with prefabricated wire harness and standard plugs

RTM X42 Receiver EMGZ482.R | Technical Data

Interface to SPS	All main protocols can be connected via an Anybus Gateway
Display	LCD 2 x 8 digits (5 mm) LED for quality of radio signal between transmitter and receiver Indication of the battery status of the transmitter
Propagation delay	≥ 10 ms
Control interface	Ethernet via web browser (Internet Explorer 7 or higher)
Radio frequency	2.44 GHz
Digital input	24 VDC galvanically isolated (impulse for continuous length registration)
Analog input	0 to 10 VDC; min. 1.2 kΩ (for core measurement)
Relay outputs	4 relay contacts, DC: 24 V/0.5 A/12 W; AC: 24 V/0.5 A/62.12 VA
Power supply	24 VDC (18 to 36 VDC) / 10 W (max. 0.5 A)
Temperature range	0 to 50°C [32 to 122 °F]
Protection class	IP 52
Weight	0.65 kg [1.43 lbs]

RTM X42 Transmitter EMGZ482.T | Technical Data

Measuring error	< 0.05 % FS
Sensor supply	3.0 VDC, max. 20 mA, highly stable
Power supply	3.7 V battery pack Li Ion (20 Ah)
Radio frequency	2.44 GHz
Resolution A/D converter	± 8192 digits (14 Bit)
Analog inputs	2 for force sensors @ 350 Ω (0 to 5.4 mV, max. 7.4 mV)
Temperature range	0 to 50°C [32 to 122 °F]
Protection class	IP 52
Weight	0.52 kg [1.15 lbs]

RTM X42 Extension Module EMGZ484.T | Technical Data

Measuring error	< 0.05 % FS
Sensor supply	3.0 VDC, max. 20 mA, highly stable
Power supply	via bus and power cable from transmitter EMGZ482T
Resolution A/D converter	± 8192 digits (14 Bit)
Analog inputs	for 4 force sensors @ 350 Ω (0 to 5.4 mV, max. 7.4 mV)
Temperature range	0 to 50°C [32 to 122 °F]
Protection class	IP 52
Weight	0.45 kg [1.0 lb]

RTM X42 System | Certification

ETSI Radio Certification	
Magnitude of Test (Coverage)	Article 3.2 of Directive 1999/5/EC (R&TTE Directive)
Certification	ETSI EN 300 440-2 V1.5.1 (2009-03); ETSI EN 300 440-1 V1.3.1 (2009-03)
FCC Certification USA, Canada	
Magnitude of Test (Coverage)	Class A digital device, pursuant to Part 15 of the FCC Rules
Certification	FCC Registration #: 0020311882
CAB Radio Certification for Japan	
Magnitude of Test (Coverage)	Low power data communi. FXD; Art. 38-24, Paragraph 1 of radio law
Certification	Article 2, Clause 1 Item 19, Certification ID #: 202WWSM10126721
Lloyd's Register	
Magnitude of Test (Coverage)	Appraisal Document No. HTS/ETS 37656-18 Certification
Certification	Lloyd's Register Type Approval Certificate No. 18/20083



Telemetry Systems | System Extensions and Accessories

RTM X42.CC Control Center



RTM X42.BC Brake Control

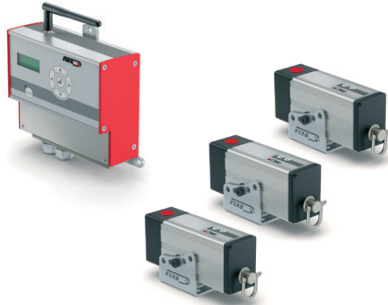

BUS Components, cabinet



The range of accessories for the RTM X42 Telemetry Systems is characterized by its modularity. The basic system for tension measurement of wires or strands can be extended gradually. The RTM X42.CC Control Center offers tools for best quality documentation and process safety. A fully equipped RTM X42 system will additionally include the RTM X42.BC Brake Control which provides continuous, automatic wire tension control.

RTM X42 Options	
Transmitter with 24 VDC power supply	Transmitter w/o battery pack if 24 VDC supply is available on the machine
Sheeves for force sensors	Design and manufacturing on request
Installation and start-up	Our specialist offer the best site support

Other FMS Products for the Wire & Cable Industry

FMS offers a wide range of measuring sensors that can all be used in combination with our telemetry systems. A huge variety of nominal sizes (3 to 8000 N) and designs offers solutions for almost any application. FMS measuring amplifiers and tension controllers are applicable when wireless data transmission is not required or when wiring of the components is not an issue. Rely on us and our proven technology in this field. Contact us directly to get more information about our portfolio of analog and digital devices as well as our bus capabilities.

Telemetry Systems | Accessories

**RMGZ 200
Measuring Rollers**



**RMGZ 300
Measuring Rollers**



EMGZ Measuring Amplifiers



CMGZ Tension Controllers



RTM X42 | Application in Cage Type Stranding Machine



RTM X42 | Application in Tubular Type Stranding Machine

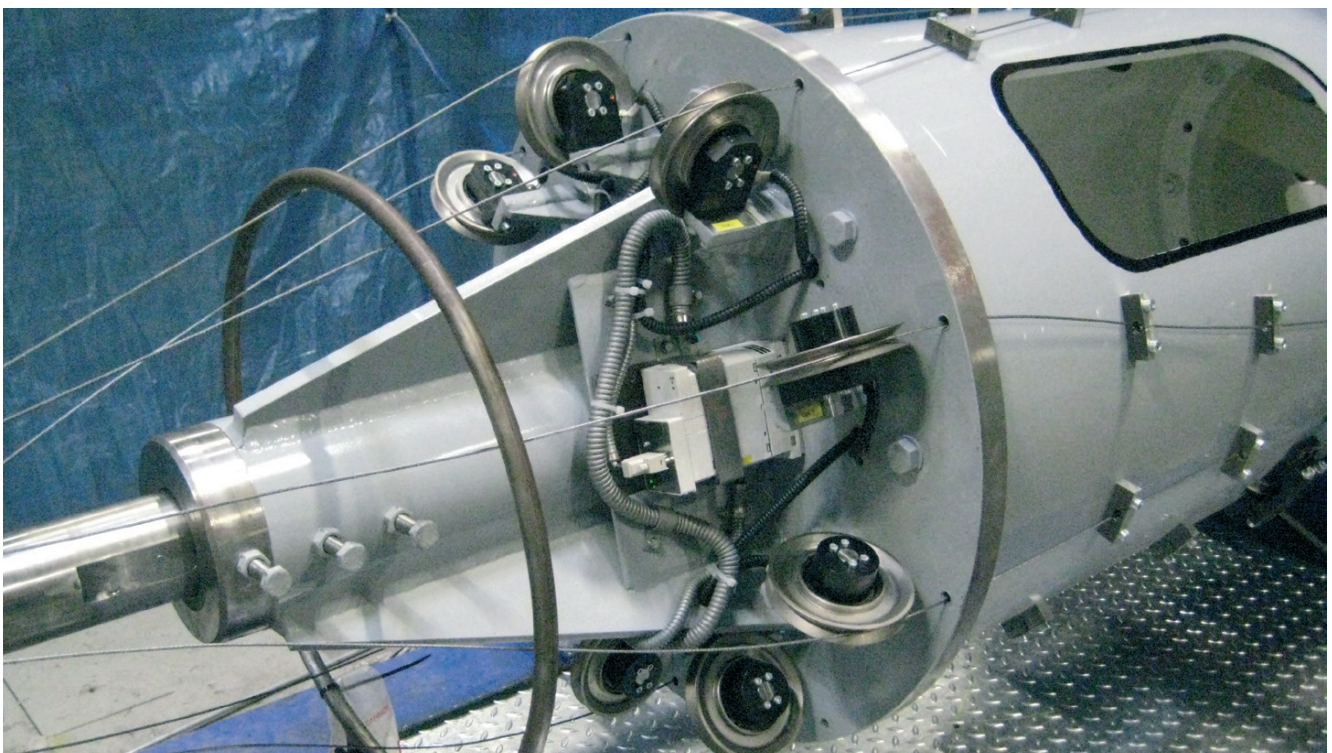

RTM X42 Receiver EMGZ482R | Dimensions in mm or [in]

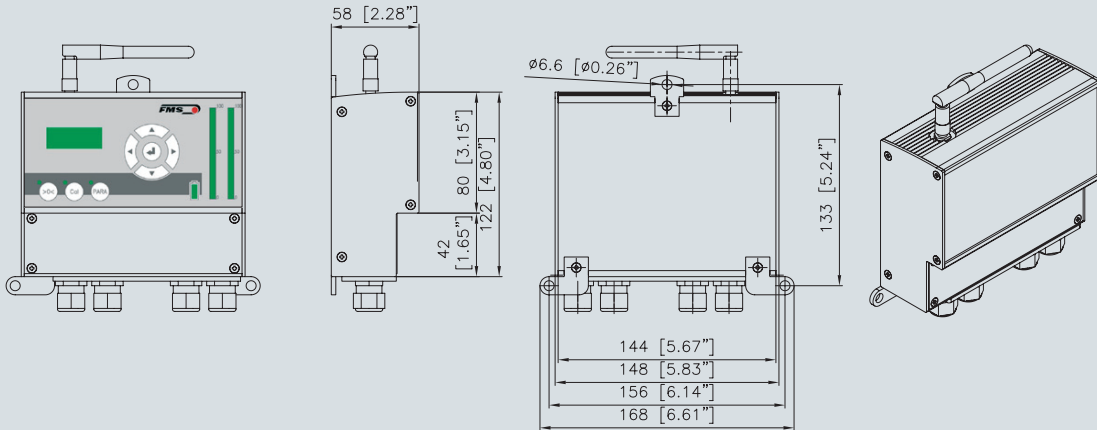

RTM X42 Transmitter EMGZ482T | Dimensions in mm or [in]

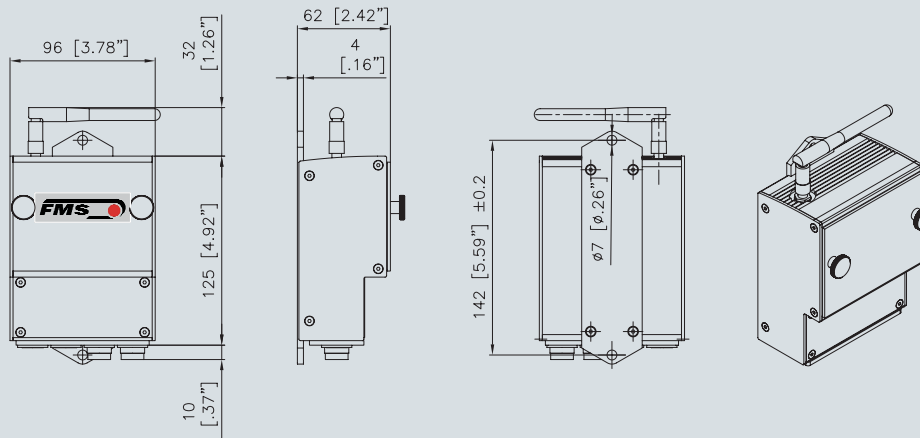

RTM X42 Extension Module EMGZ484T | Dimensions in mm or [in]

